

PRESS NOTICE

NOTICE INVITING e-TENDER

The Executive Engineer, Tezu Division, PWD, AP, Tezu on behalf of the Governor of Arunachal Pradesh invites online item rate tenders/Bids for the work **“Construction of C.C. Road in Tezu Township”** Bid No. **TDW/NIT-15/SPA/2022-23/03**.

The detailed terms and conditions of the tender / bid and bidding documents can be downloaded from the website: www.arunachaltenders.gov.in from **20/12/2022** onwards. It can also be viewed at www.arunachalpwd.org.

Executive Engineer,
Tezu Division, PWD,
Tezu (AP).



GOVERNMENT OF ARUNACHAL PRADESH
PUBLIC WORKS DEPARTMENT
EASTERN ZONE (PWD)

TENDER DOCUMENT
FOR ROAD PROJECT

BID NO. TDW/NIT-15/SPA/2022-23/03

“Construction of C.C. Road in Tezu Township”.
VOLUME-I

Certified that this Tender/Bidding document contains 134 pages including cover pages in Volume-I.

Executive Engineer
Tezu Division, PWD
Tezu

Sd/-
Superintending Engineer
Tezu Circle, PWD, Tezu
Tezu

Sd/-
CHIEF ENGINEER,
EASTERN ZONE, PWD,
NAMSAI, AP

BLANK

**GOVERNMENT OF ARUNACHAL PRADESH
OFFICE OF THE EXECUTIVE ENGINEER : TEZU DIVISION :
AP: PWD: TEZU**

IMPORTANT EVENTS & DATES

NAME OF WORK :- Construction of C.C. Road in Tezu Township.

Sl.No	Name of Events		Time of occurrences
1	Completion Period of Construction	:-	24 (Twenty four) Months.
2	Date of Online Publication	:-	20/12/2022
3	Period of availability of Bidding Documents on website www.arunachaltenders.gov.in	:-	20/12/2022 to 04/01/2023
4	Document download Start date	:-	20/12/2022
5.	Document download End date	:-	04/01/2023 upto 1000 Hrs.
6.	Bid Submission Start date	:-	20/12/2022 from 1100 Hrs.
7.	Bid Submission End date	:-	04/01/2023 upto 1100 Hrs.
8.	Last date and time of physical submission of EMD and tender fee	:-	02/01/2023 upto 1100 Hrs.
9.	Date and time of Opening Bid	:-	04/01/2023 at 1530 Hrs.
10.	Pre-Bid Meeting	:-	02/01/2023(1100 Hrs) at Office of the Executive Engineer, Tezu Division, PWD, AP, Tezu.
11.	Authority to whom EMD physically to be submitted	:-	Executive Engineer Tezu Division PWD, AP, Tezu, Arunachal Pradesh.
12	Place of Opening of Bids.	:-	Office of the Executive Engineer, Tezu Division, PWD, AP, Tezu, Arunachal Pradesh.
13	Bid Validity.	:-	120 (one hundred twenty) days from date of opening of Bid.
14	Address for Communication.	:-	Executive Engineer, Tezu Division, PWD,AP, Tezu, Lohit District, Arunachal Pradesh Pin - 792001.

BLANK

PRESS NOTICE

NOTICE INVITING e-TENDER

The Executive Engineer, Tezu Division, PWD, AP, Tezu on behalf of the Governor of Arunachal Pradesh invites online item rate tenders/Bids for the work **“Construction of C.C. Road in Tezu Township”** Bid No. **TDW/NIT-15/SPA/2022-23/03**.

The detailed terms and conditions of the tender / bid and bidding documents can be downloaded from the website: www.arunachaltenders.gov.in from **20/12/2022** onwards. It can also be viewed at www.arunachalpwd.org.

Executive Engineer,
Tezu Division, PWD,
Tezu (AP).

BLANK

**INVITATION FOR BID
(IFB)**

BLANK

GOVT. OF ARUNACHAL PRADESH
OFFICE OF THE EXECUTIVE ENGINEER, TEZU DIVISION, PWD, AP
NATIONAL COMPETITIVE BIDDING
INVITATION FOR BIDS (IFB)

Online item rate tenders are invited on behalf of the Governor of Arunachal Pradesh from all eligible registered contractors in appropriate class registered under Arunachal Pradesh Enlistment of Contractor in Work Department Rules 2008 amended up to October-2018 in **Two Bid System** (Technical Bid and Financial Bid).

Sl No	BID No.	Name of work	Estimated cost put to Tender.	Earnest Money/Bid Security	Cost of Bidding document (in Rs.)	Period of completion.
1	TDW/NIT-15/SPA/2022-23/03	"Construction of C.C. Road in Tezu Township".	Rs. 4390.00 Lakhs	1. Rs. 43.90 Lakhs (For APST) 2. Rs. 53.90 Lakhs (For Non-APST)	5000.00	24 (Twenty four) months

The period of availability of online bid/ date and time of pre-bid meeting/ date and time of online bid submission and date and time of opening of the bids are given as under;

Availability of tenders online for bidders		Date and Time of Pre-Bid Meeting	Start and end date and time for online submission of bids	Date and Time of opening of Bids	
From	To			Technical Bids	Financial Bids
20/12/2022	04/01/2023	02/01/2023 at 1100 Hrs	20/12/2022 (1100 hrs) to 04/01/2023 (1000 hrs)	04/01/2023 at 1530 Hrs.	To be notified later

- Bidding documents must be downloaded from the website www.arunuchaltenders.gov.in and the bidding documents downloaded from the website should not be tampered and if any such tampering is noticed before and after the opening of the bids, the bidders shall be penalized and blacklisted.
- The bids can be deposited in electronic format in the website www.arunuchaltenders.gov.in before the time specified by paying the cost of the bidding documents (non-refundable) in the form of demand draft of Rs. 5000/- (Rupees Five Thousand) on any scheduled bank drawn in favour of "**Executive Engineer, Tezu Division, PWD, AP**" payable at SBI Tezu, Arunachal Pradesh for the work listed in the tender. The copy of Bid feed document and receipt of Bid fee issued by the Executive Engineer shall be scanned and uploaded to the e-tendering website by the intending bidders within the period of bid submission, failing which the bid shall be rejected.
- The original EMD should be deposited in the Office of the Executive Engineer, Tezu Division PWD upto 1100 Hrs 02/01/2023. The EMD receiving Executive Engineer shall issue a receipt of deposition of earnest money deposit to the bidder in a prescribed format. This receipt shall be uploaded to the e-tendering website by the intending bidders within the period of bid submission, failing which the bid shall be rejected.

6. Earnest Money in the form of Demand Draft/Term Deposit Receipt/Fixed Deposit Receipt and DD of Tender paper cost shall be scanned and uploaded to the e-tendering website within the period of tender submission.
7. In the larger interest of the public and for equitable distribution of development works amongst eligible contractors and also to ensure effective management and quality of works, a contractor shall be allowed to have only 3 (three) works in hand in any of departments under Government of Arunachal Pradesh at a time and for which he shall make a declaration to be executed in an Affidavit that he is not engaged in more than two tenders work under the State Government of Arunachal Pradesh to be eligible to participate in this tender work.
8. Intending bidder is eligible to submit the bid provided he has definite proof from the appropriate authority, which shall be to the satisfaction of the competent authority of having satisfactorily completed similar works of magnitude specified below.

3 (three) similar works each of value not less that 40% of estimated cost put to Tender or 2 (two) similar works each of value not less than 60% of estimate cost put to Tender or 1 (one) similar work of value not less than 80% of estimated cost put to Tender (rounded off to nearest the ten thousand rupees) in the last five years ending the last day of the month previous to the 1 (one) in which the tenders are invited [Similar work means C.C. road work (Embankment construction, C.C. Road with DLC and PQC and C.D. Structures].
9. Before submission of online bids, the bidders must ensure that the scanned copy of all the necessary documents have been attached with the Bids. The details of the cost of documents and the Earnest money/Bid Security specified in the tender document should be same as submitted online (Scanned copies), otherwise will be summarily rejected. The department does not take any responsibility for delay caused due to non-availability or slow internet connection or network, traffic jam etc for online bids.

(i) The physical EMD and DD of Tender paper cost shall be deposited before bidding of Tender, failing which the bid shall be rejected and enlistment of the agency shall be withdrawn by the enlisting authority. The agency shall be debarred from tendering in APPWD. The bidders should keep checking the website for any addendum / corrigendum to the notice/ bidding documents till the last date of online submission of bids and the bidders should incorporate the same in their bidding documents.
10. The bidders should submit the GST registration certificate and record of evidence for submission of latest upto August end 2022 GST return (GSTR-3B).
11. All the construction machineries, tools and plants shall be in the name of the respective bidders in support of which the bidder shall upload ownership documents, failing which the bid shall be rejected. The Registration Certificate & Insurance of all machineries submitted by the bidders shall be scrutinized through online verification system. *(No hire/lease of any construction machineries is allowed for tender purpose)*
12. The bids will be opened online as per time schedule mentioned in this IFB in the presence of bidders who desires to attend on the scheduled date and time in the office of the Executive Engineer, Tezu Division, PWD, Arunachal Pradesh, Tezu. If the office happens to be closed on the date of opening of the bids as specified, the bids will be opened on the next working day at the same venue and time.
13. The bids must be accompanied by the Earnest money/bid security of the amount specified for the Project/ Work in this IFB payable at SBI, Tezu and drawn in favour of **Executive Engineer, Tezu Division, PWD, AP, Tezu**. Earnest money/Bid security should have a validity of 45 (forty-five) days beyond the validity of the Bid.

14. The original document for the cost of documents and the Bid Security in the form specified in the bidding document should be deposited with the Executive Engineer, Tezu Division, PWD, AP, Tezu before opening of the Technical Bid as given in this IFB, failing of which the bidder shall be disqualified.
15. Bid document consisting of disqualification information and eligibility criteria for bidders, specifications, drawings, the schedule of quantities of the various classes of the work to be done and set of terms and conditions of contract to be compiled with by the contractors can be seen on website: www.arunachaltenders.gov.in and scanned copies of the required documents and information as per Section-2 (Formats and Annexure) should be attached in the Technical Bid as prescribed in SBD.
16. Uploaded documents of valid successful bidders will be verified with the original before signing the Agreement. The valid successful bidder has to provide the original to the concerned authority on receipt of such letter, which will be sent through registered post/e-mail.
17. Bids once submitted cannot be resubmitted or withdrawn after the proposal due date and time.
19. Conditional bids and the bids not meeting the qualification criteria on the date of receipt of bids shall be summarily rejected.
20. The pre-bid meeting will be held as specified in the table above in the office of the Executive Engineer, Tezu Division, PWD, Arunachal Pradesh, Tezu to clarify the issues and to answer on any matter that may be raised at that stage as stated in Clause 9.2 of the "Instructions to Bidders" bidding document.
21. **Instruction to Bidders regarding e-tendering.**
 - (a) The interested bidders can download the bids from website www.arunachaltenders.gov.in
 - (b) To participate in the bidding process, bidders have to get "Digital Signature Certificate" as per information Technology Act-2000 to participate in on-line bidding. This Certificate will be required for digitally signing the bid. Bidders can get above mentioned digital certificate from any approved vendors/Authorized Certifying Agency. The digital Signature is mandatory to participate in e-tendering. Bidders, who already possess valid Digital Certificate need not to procure new Digital Certificate, can use the same in this tender.
 - (c) The bidders have to submit their bids on-line in electronic format with Digital Signature. The bids proposed without Digital Signature will not be accepted. No proposal will be accepted in physical form.
 - (d) No PA (Power of Attorney) holder shall be allowed to participate in this tender. Bids will be opened on-line as per time schedule mentioned in para2.
 - (e) Before submission on on-line bids, bidders must ensure that scanned copy of all the necessary documents have been attached with bid.
 - (f) The department will not be responsible for delay in online submission due to any reasons.
 - (g) All the required information for bid must be filled and submitted on-line.
 - (h) Bidders should get ready with scanned copies of the cost of documents EMD and other documents as specified in the tender documents.

- (i) The details of cost of documents, EMD specified in the tender documents should be the same as submitted on-line (Scanned copies) otherwise the bid will be summarily rejected.
 - (j) Bidders can contact the undersigned for any guidance for getting DSC or any other relevant detail in respect of e-tendering.
22. The other details can be seen in the bidding documents.
Bidders may see the note on the e-tendering procedure – Instruction to bidders ~~portal of the Ministry of Road Transport & Highways (MORTH)~~ **accompanying this IFB.**
23. Accessing/ Purchasing of Bid Documents:-
- (i) It is mandatory for all the bidders to have class-II/III Digital Signature Certificate with signing & encryption facility (in the name of person who will sign the proposal) from any of the licensed certifying Agency.
 - (ii) User may test the working condition of their Class-II/III Digital Signature Certificate (Both DSC components, i.e. signing and encryption) at under “Test Digital Signature Certificate” link.
 - (iii) All profile activation will be done only during PWD/MORTH working days. In order to submit bid response the activation of the vendor profile is mandatory.
 - (iv) The bid documents can be viewed / downloaded from e-tender portal of **www.arunachaltenders.gov.in from 20/12/2022 (11:00 AM) to 04/01/2023 (10:00 AM).**
 - (v) To participate in this Bid, bidders have to pay Rs. 5000/- (Rupees Five thousand) Only towards fee for bid documents (non-refundable) in the form of demand draft issued from a scheduled bank in India in favour of **Executive Engineer, Tezu Division, PWD, AP, Tezu.**
 - (vi) Following may be noted:-
 - (a) The enlistment of the contractors should valid on the last date of submission of bids. In case the last date of submission of bid is extended, the enlistment of contractor should be valid on the original date of submission of bids.
 - (b) Proposals can be submitted only during the validity of their registration.
 - (c) The amendments/ clarifications to the bid documents, if any will be hosted on the website www.arunachaltenders.gov.in.
 - (d) The original copy of the following documents must be submitted before opening of the Technical Bid as given in this IFB:
 - (i) Cost of Bid in the form of demand draft.
 - (ii) Bid Security or EMD.
 - (iii) Affidavit as specified in Section-2 of the Bid document
 - (iv) Bank Certificate as specified in Section-2 of the Bid document

- (e) **A hard Copy of the Technical Bid submitted online is to be submitted before opening of the Technical Bid for evaluation purpose. For any discrepancy between the online bid and the hard copy of the bid, the online bid will govern and will be considered for evaluation.**
- (f) The bids should be properly prepared with indices, with page marking, as per Format provided in the RFB in the sequence with reference to various clauses for ease of evaluation.
- (g) The interested bidders should note the following while submitting their bids and an undertaking in this regards should be submitted alongwith the bids which will form part of the agreement.
- (i) The work has been sanctioned but awaiting fund allocation during the current financial year 2022-23. Bidder shall take this in to consideration while submitting their bids.
- (ii) Work shall only be awarded to the successful bidder on confirmation of funds.
- (iii) Detailed working plan of men/materials/T&P will be submitted immediately on award by successful bidder when LOA is issued.

Signature of authorized officer



**Executive Engineer
Tezu Division, PWD, AP
Tezu**

No. TDW/NIT-15/SPA/2022-23/03/1956-63

Dated 08/12/2022

Copy to:-

1. The Commissioner (PWD), Govt. of Arunachal Pradesh, Itanagar for kind information please.
2. The Secretary, Department of Planning, Government of Arunachal Pradesh, Itanagar for kind information please.
3. The Chief Engineer, Eastern Zone, PWD, AP, Namsai for information and wide publicity please.
4. The Superintending Engineer, Tezu / Khonsa / Jairampur Circle, PWD, AP for information, and wide publicity please.
5. The Deputy Commissioner, Lohit District, Tezu, for information and wide publicity please.
6. Notice Board.



**Executive Engineer
Tezu Division, PWD, AP
Tezu**

BLANK

PROCEDURE UNDER E-TENDERING- INSTRUCTION TO BIDDERS

DEFINITIONS

- a. ~~CPPP: The Central Public Procurement Portal of the Government of India facilitates the Central Government Organisations to publish their Tender Enquiries, Corrigendum and Award of Contract Details.~~
- b. ~~MORTH e Procurement Portal: An e-tendering portal of Ministry of Road Transport & Highways (“MORTH”) introduced for the process of e-tendering. The tender has been floated as an e-tender which can be accessed on (www.arunachaltenders.gov.in).~~

1. Accessing/ Purchasing of RFP documents

- i) It is mandatory for all the bidders to have **class II or class-III Digital Signature Certificate** from any of the licensed Certifying Agency (Bidders can see the list of licensed CA’s from the link www.cca.gov.in) to participate in e-tendering. Please note over portal is irrespective of DSC type i.e it will work with both signing and encryption and only signing but is recommended for the bidder to have a DSC with both signing and encryption certificate.
- ii) To participate in the E-Bid submission, it is mandatory for the bidders to register their firm with the e-tendering portal of Ministry of Road Transport & Highways Govt. of AP (www.arunachaltenders.gov.in).
- iii) The RFP/ Bid Document can be viewed or downloaded from the e-tendering portal www.arunachaltenders.gov.in.
- iv) Bidders can participate using the e-tender portal in www.arunachaltenders.gov.in. Following is to be noted.
 - a) Registration at e-tendering portal www.arunachaltenders.gov.in should be valid at least upto the date of opening of financial bid.
 - b) Proposals can be submitted only during the validity of their registration.
 - c) The amendments/clarifications to the RFP document, if any, will be hosted on the website www.arunachaltenders.gov.in.
 - d) If the firm is already registered with the e-tendering portal of www.arunachaltenders.gov.in and validity of registration is not expired, the firm is eligible to apply without fresh registration.

2. Preparation and Submission of Proposal

- i) The response to the RFP /Bid Notice/ IFB /the bid document should be submitted online only along with the hard copy of the supporting documents as mentioned in the IFB.
- ii) RFP/Bid Document may be downloaded from the e-tender portal of www.arunachaltenders.gov.in as per the schedule mentioned in IFB and tender may be submitted online following the instruction appearing on the screen.
- iii) All documents which are required to be submitted as per bidding document stipulation shall be prepared and scanned in different files (in PDF of ZIP format), such that the file size is not more than 30 MB and uploaded during the online submission of the proposal. The following documents shall also be submitted in “ORIGINAL” before opening of the Technical Bid as given in this IFB in the Office of the Executive Engineer, Tezu Division, PWD, AP, Tezu.
 - a) Cost of Bid in the form of demand draft.
 - b) Bid Security or EMD
 - c) Affidavit as specified in Section-2 of Bid Document
 - d) Bank Certificate as specified in Section -2 of Bid Document.

- iv) The Hard Copy of the Technical Bid submitted online shall also be submitted in a sealed envelope for evaluation purpose. For any discrepancy between the online bid and the hard copy of the bid, the online bid will govern and will be considered for evaluation. The Hard Copy of the Technical Bid shall be submitted before the time of **Technical Bid opening**.
- v) This department shall not be held responsible for non-receipt of the hard copies mentioned above on account of postal delays/ delayed physical submission.

The Bidder shall submit the Hard Copy with reference no. with the Heading as Technical Bid for "Construction of C.C. road in Tezu Township".

Bid No. TDW/NIT-15/SPA/2022-23/03 and "NOT TO BE OPENED BEFORE 1530 Hrs on 04/01/2023

The Envelope shall be addressed to:

**Executive Engineer
Tezu Division, PWD, AP
Tezu, Pin - 792001**

- vi) In the Financial Bid, the item-wise rate should be quoted inclusive of all taxes and should only be submitted online in the e-tendering portal and **not as hard copy. Bidders submitting the financial proposal as hard copy would be disqualified.**
- vii) For any assistance, about the tendering, the **Executive Engineer, Tezu Division, PWD** may be contacted. Additionally, the Bidders can e-mail their issues to eepwdtezu@gmail.com. These facilities are available between 1000 Hrs to 1700 Hrs IST (Monday to Friday) (Exclusions : PWD/Govt HOLIDAYS/Saturday and Sundays).

3. Modification/ Substitution/ Withdrawal of Proposals

- i) The Bidder may modify, substitute or withdraw its e-bid after submission prior to the proposal due date. No proposal shall be modified, substituted or withdrawn by the Bidder after the proposal due date and time.
- ii) Any alteration/ modification in the proposal or additional information supplied subsequent to the proposal after the due date, unless the same has been explicitly sought for by the ~~Ministry of Road Transport & Highways/~~ PWD, Arunachal Pradesh, shall be disregarded.
- iii) For modification of E-Bid, Bidder has to replace its old proposal from the e-tendering portal and upload/ resubmit the digitally signed modified proposal.
- iv) For withdrawal of proposal, bidder has to click on withdrawal icon in the e-tendering portal and withdraw the bid.
- v) **In case of any variance between the amount quoted in the Form of Bid (FOB) and the system generated total amount of Bill of quantity (BOQ) (Without any correction of errors as per clause 27 of ITB) the variance is to be explained/clarified/justified by the bidder. In absence of such explanation / clarification/ justification, the FOB amount will be discarded and the BOQ amount will be taken as the Bid Price, irrespective of the BOQ amount being higher or lower than the FOB amount.**

4. List of Documents to be scanned and uploaded within the period of tender submission:

When Internet based Electronic Tendering is being used, the following Technical documents are to be scanned, uploaded and submitted online. Financial bid must be submitted online only.

- (i) Copy of receipt of cost of Tender document, copy of receipt for deposition of Original EMD to Executive Engineer, Tezu Division, PWD, AP, Tezu, copy of instrument of EMD and cost of tender document.
- (ii) Enlistment Order of the Contractor.
- (iii) Certificates of similar Work Experience.
- (iv) GST registration Certificate.
As per the latest Government notification, it is mandatory on the part of all the Organization and establishment to file GST returns on regular basis. All intending bidders **shall submit Proof of filing of GST returns on regular basis** failing which bids are liable to be rejected. Latest **GSTR-3B** up to dated **October/2022** shall be uploaded with undertaking of its authenticity.
- (v) Schedule Tribe Certificate (APST)
- (vi) Pan Card.
- (vii) The bidder(s)/tenderer(s) will have to produce no dues certificate (NDC)/No objection certificate (NOC) from the Arunachal Pradesh State Co-operative Apex Bank Ltd., duly issued by the Managing Director cum Chief Executive Officer, Itanagar alongwith the bid/tender in order to participate. However, this condition may be relaxed for bidders of states other than Arunachal Pradesh, at the discretion of the tender accepting authority.
- (viii) Bank Solvency Certificate for an amount of Rs. 1756.00 Lakhs (Rupees Seventeen crores fifty six lacs) only.
- (ix) Annual turnover for the immediate last five consecutive years duly certified by the Chartered Accountant.
- (x) Affidavit of T&P with supporting details.
- (xi) Affidavit on list of Works in hand/Ongoing commitments.
- (xii) Current litigation in which the bidder is involved.
- (xiii) Signed copy of undertaking of Terms and Conditions of Tender.
- (xiv) Affidavit of Technical Representatives with supporting details.
- (xv) Undertaking for Bid Validity.
- (xvi) Undertaking for minimum cash investment up to 25% of contract value of work, during implementation of work.

- (xvii) Affidavit for no near relatives working in the department.
- (xviii) Affidavit on correctness / truth fullness of information furnished by Bidder.
- (xix) All other papers / documents not mentioned above but specified in bid document and papers/ documents in support of affidavit / undertaking wherever required.
- (xx) Affidavit regarding site visit / inspection by the contractor.
Site visit certificate shall be issued by the concerned Engineer-in-charge after satisfying themselves by visiting the site alongwith the bidders. The bid without site visit report duly countersigned by the Engineer-in-charge (EE/AE) shall be summarily rejected.
- (xxi) Correspondence address, mobile No., e-mail ID of proprietor/firm must be furnished in separate sheet.

NOTE: The solvency certificate, affidavits, undertaking and other information (that lapse with time) shall not be more than 3 (three) months old.

DISCLAIMER

The Applicant must read all the instructions in the TENDER and submit the same accordingly. For any support/ assistance they may contact helpdesk officers.

SECTION-1
INSTRUCTION TO BIDDERS
(ITB)

BLANK

Section I: Instructions to Bidders

Table of Clauses

A. General

1. Scope of Bid
2. Source of Funds
3. Eligible Bidders

4. Qualification of the Bidder

5. One Bid per Bidder
6. Cost of Bidding
7. Site Visit

B. Bidding Documents

8. Content of Bidding Document
9. Clarification of Bidding Documents
10. Amendment of Bidding Documents

C. Preparation of Bids

11. Language of Bid
12. Documents Comprising the Bid
13. Bid Prices
14. Currencies of Bid and Payment
15. Bid Validity
16. Bid Security
17. Alternative Proposals by Bidders
18. Format and Signing of Bids

D. Submission of Bids

19. Sealing and Marking of Bids
20. Deadline for Submission of Bids
21. Late Bids
22. Modification and Withdrawal of Bids

E. Bid Opening and Evaluation

23. Bid Opening
24. Process to be Confidential
25. Clarification of Financial bids
26. Examination of Bids and Determination of Responsiveness
27. Correction of Errors
28. Deleted
29. Evaluation and Comparison of Financial Bids
30. Deleted

F. Award of Contract

31. Award Criteria
32. Employer's Right to Accept any Bid and to reject any or all Bids
33. Notification of Award and Signing of Agreement
34. Performance Security
35. Advance Payment and Security
36. Dispute Review Expert
37. Corrupt or Fraudulent Practices

BLANK

GENERAL

1. Scope of Bid

- 1.1 The Employer (named in Appendix to ITB) invites bids for the construction of works (as defined in these documents and referred to as “the works) detailed in the table given in IFB. The bidders may submit bids for any or all of the works detailed in the table given in IFB.
- 1.2 The successful bidder will be expected to complete the works by the intended completion date specified in the Contract data.
- 1.3 Throughout these bidding documents, the terms “bid” and “tender” and their derivatives (bidder/tenderer, bid/tender, bidding/tendering, etc.) are synonymous.

2. Source of Funds

- 2.1 The expenditure on this project will be met from SPA/ budget of Govt. of India/ Arunachal Pradesh.

3. Eligible Bidders

- 3.1 This invitation for Bids is open to all bidders.
- 3.2 All bidders shall provide in Section 2, Forms of Bid and Qualification Information, a statement that the Bidder is neither associated, nor has been associated, directly or indirectly, with the Consultant or any other entity that has prepared the design, specifications, and other documents for the Project or being proposed as Project Manager for the Contract. A firm that has been engaged by the Employer to provide consulting services for the preparation of supervision of the works, and any of its affiliates shall not be eligible to bid.

4. Qualification of the Bidder

- 4.1 All bidders shall provide in Section 2, Forms of Bid and Qualification Information, a preliminary description of the proposed work method and schedule, including drawings and charts, as necessary. The proposed methodology should include programme of construction backed with equipment planning and deployment duly supported with broad calculations and quality assurance procedures proposed to be adopted justifying their capability of execution and completion of work as per technical specifications, within stipulated period of completion.

- 4.2* ~~In the event that Pre qualification of potential bidders has been undertaken, only bids from pre qualified bidders will be considered for award of Contract. These qualified bidders should submit with their bids any information updating their original pre qualification applications or, alternatively, confirm in their bids that the originally submitted pre qualification information remains essentially correct as of date of bid submission. The update or confirmation should be provided in Section 2. A copy of the original pre qualification application and the letter of pre qualification should be furnished.~~

~~With the updated information, the bidder must continue to be qualified in accordance with the criteria laid down in the pre qualification document. All bidders shall also furnish the following information in Section 2.~~

- ~~(i) Evidence of access to or availability of credit facilities (minimum 10% of notified contract value) certified by the bankers.~~
- ~~(ii) Undertaking that bidder would be able to invest a minimum of cost upto 25% of the contract value of work, during implementation of contract.~~
- ~~(iii) Proposals, if any, for sub contracting of elements of work, costing more than 10% of the bid amount.~~

~~(iv) Power of attorney.~~

~~(v) Latest income tax clearance certificate from concerned department.~~

***{Clause 4.2 is not applicable as post qualification is to be carried out}.**

4.3 If the Employer has not undertaken pre-qualification of potential bidders, all bidders shall include the following information and documents with their bids in Section 2.

- (a) Copies of original documents defining the constitution of legal status, place of registration, and principal place of business; written power of attorney of the signatory of the Bid to commit the Bidder.
- (b) Total monetary value of construction work performed for each of the last five years.
- (c) Experience in works of a similar nature and size for each of the last five years, and details of works underway or contractually committed; and clients who may be contracted for further information on those contracts [Similar work means road work (Embankment construction, C.C. road, C.C. drain and CD structure)].
- (d) Major items of construction equipment proposed to carry out the Contract.
- (e) Qualifications and experience of key site management and technical personnel proposed for Contract.
- (f) Reports on the financial standing of the Bidder, such as profit and loss statements and auditor's report for the past five years;
- (g) Evidence of access to line (s) of credit and availability of other financial resources facilities (10% of contract value), certified by the Bankers (not more than 3 months old).
- (h) Undertaking that the bidder will be able to invest minimum cash up to 25% of contract value of work, during implementation of work.
- (i) Authority to seek references from the Bidder's bankers;
- (j) Information regarding any litigation, current or during the last five years, in which the Bidder is involved, the parties concerned, and disputed amount.
- (k) ~~Proposals for subcontracting components of the Works amounting to more than 10 percent of the Bid price (for each, the qualifications and experience of the identified sub-contractor in the relevant field should be annexed); and~~
- (l) The proposed methodology and programme of construction, backed with equipment planning and deployment, duly supported with broad calculations and quality control procedures proposed to be adopted, justifying their capability of execution and completion of the work as per technical specifications within the stipulated period of completion as per milestones.

4.4 Deleted

4.5 .QUALIFICATION CRITERIA

4.5.1, Qualification will be based on Applicant's meeting all the following minimum pass/fail criteria regarding the Applicant's general & particular experience, personnel and equipment capabilities, and financial position, as demonstrated by the Applicant's responses in the forms attached to the Letter of Application(specified requirements for joint ventures are given under para 4.6 below). Subcontractor's

experience and resources shall not be taken into account in determining the applicant's compliance with the qualifying criteria.

~~To qualify for more than one contract, the applicant must demonstrate having experience and resources sufficient to meet the aggregate of the qualification criteria for each contract given in paragraphs 4.5.4, 4.5.5, 4.5.6 & 4.5.9 below.~~

4.5.2- Base year and Escalation.

The base year shall be taken as 2021-22.

Following enhancement factors will be used for the costs of works executed and the financial figures to a common base value for works completed in India.

<u>Year before.</u>	<u>Multiplying factor.</u>
One	1.10
Two	1.21
Three	1.33
Four	1.46
Five	1.61

Applicant should indicate actual figures of costs and amount for the works executed by them without accounting for the above mentioned factors.

In case of financial figures and value of completed works are in foreign currency, the above enhanced multiplying factors will not be applied. Instead, current market exchange rate (State Bank of India BC selling rate as on the last date of submission of the bid) will be applied for the purpose of conversion of amount in foreign currency into Indian Rupees.

4.5.3 General Experience:

The Applicant shall meet the following minimum criteria:

(a) Average annual turnover (defined as billing for works in progress and completed in all classes of civil engineering construction work only) over the last 5 years of 40% of the value of contract/contracts applied for as indicated in the Appendix.

(b) Three similar works each value not less than 40% of estimate cost or 2 (two) similar works each of value not less than 60% of estimate cost or 1 (one) similar work of value not less than 80% of estimated cost (rounded off to nearest the ten thousand rupees) in the last five years ending the last day of the month previous to the 1 (one) in which the tenders are invited [Similar work means road work (Embankment construction, C.C. road, C.C. drain and CD structure)].

The works may have been executed by the Applicant as prime contractor or as a member of joint venture or sub contractor. As sub contractor, he should have acquired the experience of execution of all major items of works under the proposed contract. In case of project has been executed by a joint venture, weightage towards experience of the project would be given to each joint venture in proportion to their participation in the joint venture.

Substantially completed works means those works which are at least 90% completed as on the date of submission (i.e. gross value of the work done up to the last date of submission is

90% or more of the original contract price) and continuing satisfactorily. For these, a Certificate from the employer shall be submitted along with the application incorporating clearly the name of the work, Contract value, billing amount, date of commencement of works, satisfactory performance of the contractor and any other relevant information.

4.5.4 Personnel Capabilities.

The applicant must have suitably qualified personnel to fill the following positions. The applicant will supply information on a prime candidate and alternate for each position, both of whom should meet the experience requirements specified below:

Sl.No.	Position	Total experience (years)	In similar works (Years)	As manager of similar works (Years)
1	Project Manager			
2	Other positions			
(List is given in Annexure-I)				

4.5.5 Equipment capabilities

The applicant should own or should have assured ownership to the following key items of equipment, in full working order, and must demonstrate that, based on known commitments; they will be available for use in the proposed contract.

Sl.No.	Equipment type and characteristics	Minimum number required
1		
2		
3		
(List is given in Annexure-II)		

4.5.6 Financial position.

The Applicant should demonstrate that he has access to, or has available, liquid assets (aggregate of working capital, cash in hand and uncommitted bank guarantees) and / or credit facilities of not less than 10% of the value of the contract / contracts applied for (construction cash – flow may be taken as 10% of the estimated value of contract / contracts).

4.5.7 The audited balance sheet for the last five years should be submitted, which must demonstrate the soundness of the Applicant's financial position, showing long term profitability including an estimated financial projection for the next two years. If necessary, the employer will make inquiries with the applicant's bankers.

4.5.8 Litigation History.

The applicant should provide accurate information on any litigation or arbitration resulting from contracts completed or under execution by him over the last five years. A consistent history of awards against the Applicant or any partner of a joint venture may result in failure of the applicant.

4.5.9 Bid capacity :

The Applicants who meet the minimum qualification criteria will be qualified only if their available bid capacity at the expected time of bidding is more than the total estimated cost of the works. The available bid capacity will be calculated as under:

Assessed available bid capacity = $(A * N * 2 - B)$, Where

A = Maximum value of works executed in any one year during the last five years (updated to the current price level) rate of inflation may be taken as 10% per year which will take into account the completed as well as works in progress.

B = Value at current price level of the existing commitments and ongoing works to be completed during the next **24 months** (period of completion of work for which bids are invited); and

N = Number of years prescribed for completion of the works for which bids are invited.

Note : ~~{In case of a joint venture, the available bid capacity will be applied for each partner to the extent of his proposed participation in the execution of the works}...NotApplicable~~

4.5.10 Disqualification:

Even though the Applicants meet the above criteria, they are subject to be disqualified if they have:

- made misleading or false representations in the forms, statements submitted; and /or.
- Record of poor performance such as abandoning the work, rescinding of contract for which the reasons are attributable to the non performance of the contractor, consistent history of litigation awarded against the Applicant or financial failure due to bankruptcy. The rescinding of contract of a Joint Venture on account of reasons other than non performance, such as Most Experience partner of Joint Venture pulling out, court directions leading to breaking up of a Joint Venture before the start of work, which are not attributable to the poor performance of the contractor will, however, not affect the pre-qualification of the individual partners.

4.6. JOINT VENTURES (Clause no.4.6 is not applicable)

~~4.6.1. Joint Ventures must comply with the following requirements:~~

~~a) Following are the minimum qualification requirements,~~

~~i) The lead partner shall meet not less than 50% of all the qualifying criteria given in paras 4.5.3 and 4.5.6 above. The joint venture must collectively satisfy the criteria of para 4.5.3 & 4.5.6 above. The experience of the other joint venture partners shall be considered if it is not less than 30 per cent of the qualifying criteria given in paras 4.5.3. and 4.5.6 above. However, in case one of the joint venture partners is proposed to be included primarily to provide financial strength to the joint venture, such joint venture partner shall have to commit to provide liquidity support to the project to the extent of 10 percent of the value of the contract.~~

~~ii) The joint ventures must satisfy collectively the criteria of paras 4.5.4 & 4.5.5 above for which purpose the relevant figures for each of the partners shall be added together to arrive at the joint venture's total capacity. Individual members must each satisfy requirements of para 4.5.7. & 4.5.8 above.~~

~~b) The formation of a joint venture after prequalification, any change in a pre-qualified joint venture, will be subject to the written approval of the Employer prior to the deadline for submission of bids. Such approval shall be define if (i) partners withdraw from a joint venture and the remaining partners do not meet the qualifying requirements; (ii) the new partners to a joint venture are not qualified individually or as another joint venture; or (iii) in the opinion of the Employer, a substantial reduction in completion may result.~~

~~e) Bid shall be signed so as to legally bind all partners, jointly and severally, and shall be submitted with a copy of the joint venture agreement providing the ‘joint and several’ liability with respect to the contract.~~

~~4.6.2 Qualification of a joint venture does not necessarily qualify any of its partners individually or as a partner in any other joint venture. In case of dissolution of a joint venture, each one of the constituent firms may qualify if they meet all the qualification requirements, subject to the written approval of the Employer.~~

5. One Bid per Bidder

5.1.1 Each bidder shall submit only one bid for one package. A bidder who submits or participates in more than one Bid (other than as a subcontractor or in cases of alternatives that have been permitted or requested) will cause all the proposals with the Bidder’s participation to be disqualified.

6. Cost of Bidding

6.1 The bidder shall bear all costs associated with the preparation and submission of his Bid, and the Employer will in no case responsible and liable for those costs.

7. Site visit

6.1 The bidder, at the Bidder’s own responsibility and risk is encouraged to visit and examine the site of works and its surroundings and obtain all information that may be necessary for preparing the Bid and entering into a contract for construction of the works. The costs of visiting the site shall be at the bidder’s own expense.

B. BIDDING DOCUMENTS

8. Content of Bidding Documents.

8.1 The set of bidding documents comprises the documents listed below and addenda issued in accordance with clause 10;

Section	Particulars	Volume No.
	Invitation for Bids	I
1	Instructions to Bidders	
2	Qualification Information and other forms	
3	Conditions of contract	
4	Contract Data	
5	Securities and other forms	
6	Technical specifications	
7	Drawings	II
8	Form of bid and bill of quantity	

8.2 **DELETED**

8.3 The Bidder is expected to examine carefully all instructions, conditions of contract, contract date, forms, terms, technical specifications, bill of quantities, forms, Annexures and drawings in the Bid Documents. Failure to comply with the requirements of Bid Documents shall be at the bidder's own risk. Pursuant to clause 26 hereof, bids which are not substantially responsive to the requirements of the Bid Documents shall be rejected.

9. Clarification of Bidding Documents

9.1 A prospective bidder requiring any clarification of the bidding documents may notify the Employer in writing or by cable (hereinafter "cable" includes telex and facsimile) at the Employer's address indicated in the invitation to bid. The employer will respond to any request for clarification, which he received earlier than 15 days prior to the deadline for submission of bids. Copies of the Employer's response will be forwarded to all purchasers of the bidding documents, including a description of the enquiry but without identifying its source.

9.2 Pre-Bid Meeting

9.2.1 The Bidder or his official representative is invited to attend a pre-bid meeting, which will take place at the address, venue, time and date as indicated in appendix.

9.2.2 The purpose of the meeting will be to clarify issues and to answer questions on any matter that may be raised at that stage.

9.2.3 The bidder is requested to submit any questions in writing or by cable to reach the Employer not later than one week before the meeting.

9.2.4 Minutes of the meeting, including the text of the questions raised (without identifying the source of enquiry) and the responses given will be transmitted without delay to all purchasers of bidding documents. Any modification of the bidding documents listed in Sub-Clause 8.1 which may become necessary as a result of the pre-bid meeting shall be made by the Employer exclusively through the issue of an Addendum pursuant to Clause 10 and not through the minutes of the pre-bid meeting.

9.2.5 Non-attendance at the pre-bid meeting will not be a cause for disqualification of a bidder.

10. Amendment of Bidding Documents

10.1 Before the deadline of submission of bids, the Employer may modify the bidding documents by issuing addenda.

10.2 Any addendum thus issued shall be part of the bidding documents and shall be communicated in writing to all purchasers of the bidding documents. Prospective bidders shall acknowledge receipt of each addendum in writing or by cable to the Employer. The Employer will assume no responsibility for postal delays.

10.3 To give prospective bidders reasonable time in which to take an addendum in to account in preparing their bids, the Employer may, at his discretion, extend as necessary the deadline for submission of bids, in accordance with Sub-Clause 20.2 below.

C. PREPARATION OF BIDS

11. Language of the Bid

11.1 All documents relating to the bid shall be in the English language.

12. Documents comprising the Bid

- 12.1 The bid to be submitted by the bidder (refer Clause 8.1) shall be in 2(two) separate parts i.e. Technical and Price (Financial) bids :

Technical Bid shall comprise

- (i) Bid Security in the form specified in Section 8 (if furnished in the form of BG).
- (ii) Qualification information and supporting documents as specified in Section 2.
- (iii) Certificates, undertakings, affidavits as specified in Section 2.
- (iv) Any other information pursuant to Clause 4.2 of the instructions.
- (v) Undertaking that the Bid shall remain valid for the period specified in Clause 15.1
- (vi) Acceptance/non-acceptance of Dispute Review Expert proposed in Clause 36.1
- (vii) Authority to seek reference from the bidders Bankers (Clause 4.3.1)

Price (Financial) Bid shall comprise

- (i) Form of Bid as specified in Section 6.
- (ii) Priced Bill of Quantities for items specified in Section 7.

12.2 **DELETED**

- 12.3 Following documents, which are not submitted with the bid, will be deemed to be part of the bid.

Section	Particulars	Volume No.
	Invitation for Bids (IFB)	
1	Instruction to Bidders	Vol – I
2	Conditions of contract	Vol – I
3	Contract Data	Vol – I
4	Specifications	Vol – I
5	Drawings (if furnished to the bidder in the set of bid document issued)	Vol – I

13. Bid Prices

- 13.1 The contract shall be for the whole works as described in Sub-Clause 1.1, based on priced Bill of Quantities submitted by the Bidder.
- 13.2 The Bidder shall fill in rates and prices and line item total (both in figures and words) for all items of the Works described in the Bill of Quantities along with total bid price (both in figures and words). *Items for which no rate or price is entered by the bidder will not be paid for by the Employer when executed and shall be deemed covered by the other rates and prices in the Bill of Quantities.* Corrections, if any, shall be made by crossing out, initialing, dating and rewriting.
- 13.3 All duties, taxes, and other levies payable by the contractor under the contracts, or for any other cause including transportation cost shall be included in the rates, prices and total Bid price submitted by the bidder as his competitive bid. The bidders are to quote the rates at works site.
- 13.4 The rates and prices quoted by the bidder shall be fixed for the duration of the Contract and shall not be subject to adjustment on any account (~~For contracts upto 12 months period~~).

14. Currencies of Bid and Payment

- 14.1 The unit rates and the prices shall be quoted by the bidder entirely in Indian Rupees. All payments shall be made in Indian Rupees.

15. Bid Validity

- 15.1 Bids shall remain valid for period not less than 120 days after the deadline date for submission specified in Clause 20. A bid valid for a shorter period ~~shall be rejected by the Employer as non-responsive~~. In case of discrepancy in bid validity period between that given in the undertaking pursuant to Clause 12.1 (v) and the Form of Bid submitted by the bidder, the latter shall be deemed to stand corrected in accordance with the former and the bidder has to provide for any additional security that is required.
- 15.2 In exceptional circumstances, prior to expiry of the original time limit, the Employer may request that the bidders may extend the period of validity for a specified additional period. The request and the bidder's responses shall be made in writing or by cable. A bidder may refuse the request without forfeiting his bid security. A bidder agreeing to the request will not be required or permitted to modify his bid except as provided in 15.3 hereinafter, but will be required to extend the validity of his bid security for a period of the extension, and in compliance with Clause 16 in all respects.
- 15.3 In case of contracts in which the Contract Price is fixed(not subject to price adjustment), in the event that the Employer requests and the Bidder agrees to an extension of the bid validity period, the contract price, if the Bidder is selected for award shall be the bid price corrected as follows:
~~The price shall be increased by the factor of 0.2% for each week or part of a week that has elapsed from the expiration of the initial bid validity to the date of issue of letter of acceptance to the successful Bidder.~~
(Not applicable)

- 15.4 Bid evaluation will be based on the bid prices without taking in to consideration the above correction.

16. Bid Security

- 16.1 The bidder shall furnish, as part of his Bid, a Bid security in the amount as shown in column 4 of the table of IFB for this particular work. This bid security shall be in favour of the Executive Engineer, Tezu Division, PWD, Tezu as named in Appendix and may be in one of the following forms.
- Receipt in challan of cash deposit in the Govt. Treasury in India.
 - Deposit-at-call Receipt from any scheduled Indian bank or a foreign bank located in India and approved by the Reserve Bank of India.
 - Indian Post Office/National Savings Certificate duly endorsed by the competent postal authority in India.
 - ~~Bank Guarantee from any scheduled Indian Bank, in the format given in Volume I.~~
 - Fixed deposit Receipt, a certified cheque (**A certified cheque is a Bank Cheque issued by a party and certified by an authorized officer of the drawer bank branch certifying the correctness/genuineness of the cheque and irrevocably confirming the payment of the cheque as per apparent tenor of the instrument as and when presented for payment by the payee**) or an irrevocable letter of credit, issued by any Scheduled Indian bank or a foreign Bank approved by the Reserve Bank of India.
- 16.2 Bank Guarantees (and other instruments having fixed validity) issued, as surety for the bid shall be valid for 45 days beyond the validity of the Bid.
- 16.3 Any Bid not accompanied by an acceptable Bid Security and not secured as indicated in Sub-Clauses 16.1 and 16.2 above shall be rejected by the Employer as non-responsive.
- 16.4 The bid security of unsuccessful bidders will be returned within 28 days of the end of the bid validity period specified in Sub-Clause 15.1.

- 16.5 The bid security of the successful bidder will be discharged when the bidder has signed the Agreement and furnished the required Performance Security.
- 16.6 The Bid Security may be forfeited
- (a) if the Bidder withdraws the Bid after Bid opening during the period of Bid validity.
 - (b) if the Bidder does not accept the correction of the Bid price, pursuant to Clause 27; or
 - (c) in the case of a successful Bidder, if the Bidder fails within the specified time limit to
 - i) sign the Agreement; or
 - ii) furnish the required Performance Security

17. Alternative Proposals by Bidders.

- 17.1 Bidders shall submit offers that fully comply with the requirements of the bidding documents, including the conditions of contract (including mobilization advance or time for completion), basic technical design as indicated in the drawing and specifications. Conditional offer or alternative offers will not be considered further in the process of tender evaluation.

18. Format and Signing of Bid.

- 18.1 The bidders shall submit on-line one set of bid comprising of documents as prescribed Clause 12.
- 18.2 **DELETED**
- 18.3 **DELETED**

D. SUBMISSION OF BIDS.

19. Sealing and Marking of Bids.

The Bidder shall place two separate digitally signed files marked “Technical Bid” (Cover 1) and Financial Bid (Cover 2). The contents of technical and financial Bids will be specified in Clause 12.1 documents are to be signed digitally by the bidders.

- 19.1 **DELETED**
- 19.2 **DELETED**
- 19.3 **DELETED**
- 19.4 **DELETED**

20. Deadline for Submission of the Bids.

- 20.1 Complete Bids must be received by the Employer at the address specified above and not later than the date indicated in appendix. In the event of the specified date for the submission of bids declared a holiday for the Employer, the Bids will be received up to the appointed time on the next working day.
- 20.2 The Employer may extend the deadline for submission of the bids by issuing an amendment in accordance with clause 10, in which case all rights and obligations of the Employer and the bidders previously subject to the original deadline will then be subject to the new deadline.

21. Late Bids

- 21.1 **DELETED**

22. Modification and Withdrawal of Bids

- 22.1 Bidders may modify or withdraw their bids by giving notice in writing before the deadline prescribed in Clause 20 or pursuant to Clause 23.
- 22.2 Each bidder's modification or withdrawal notice shall be prepared, sealed, marked, and delivered in accordance with clause 18 & 19.
- 22.3 **DELETED**
- 22.4 Withdrawal or modification of a Bid between the deadline for submission of bids and the expiration of the original period of bid validity specified in Clause 15.1 above or extended pursuant to Clause 15.2 may in the forfeiture of the Bid security pursuant to Clause 16.

E. BID OPENING AND EVALUATION

23. Bid Opening

- 23.1 The Executive Engineer, Tezu Division, PWD, Tezu will open all the Bids received (except those received late), including modifications made pursuant to Clause 22, in the presence of the Bidders or their representatives who choose to attend at time, date and place specified in Appendix in the manner specified in Clause 20 and 23.3. In the event of the specified date of Bid opening being declared a holiday for the Executive Engineer, Tezu Division, PWD, Tezu, the Bids will be opened at the appointed time and location on the next working day.
- 23.2 Marked **"WITHDRAWAL"** shall be opened and read out first, Bids for which an acceptable notice of withdrawal has been submitted pursuant to Clause 22 shall not be opened.
- 23.3 "Technical Bid" shall be opened first. The amount, form and validity of the bid security furnished with each bid will be announced. If the bid security furnished does not conform to the amount and validity period as specified in the Invitation for Bid (ref. Column 5 and paragraph 4), and has not been furnished in the form specified in Clause 16, the remaining technical bid and the sealed financial bid will be returned to the bidder.
- 23.4
- i) Subject to confirmation of the bid security by the issuing Bank, the bids accompanied with valid bid security will be taken up for evaluation with respect to the Qualification Information and other information furnished in Part-I of the Bid pursuant to Clause 12.1.
 - ii) After receipt to confirmation of the bid security, the bidder will be asked in writing (usually within 10 days of opening of the Technical Bid) to clarify or modify his technical bid, if necessary, with respect to any rectifiable defects.
 - iii) The bidders will respond in not more than 7 days of issue of the clarification letter, which will also indicate the date, time and venue of opening of the Financial Bid (usually on the 21st day of opening of the Technical Bid).
 - iv) Immediately (usually within 3 or 4 days), on receipt of these clarification the Evaluation Committee will finalize the list of responsive bidders whose financial bids are eligible for consideration.
- 23.5 Notwithstanding any modification of rectifiable defect in technical bid carried out by a bidder in accordance with the of clause 23.4, no bidder shall be permitted to modify his financial offer after the dead line of submission of bids as indicated in appendix is over.
- 23.6 At the time of opening of "Financial Bid", the names of Bidders were found responsive in accordance with clause 23.4 (iv) will be announced. The bids of only these bidders will be opened. The remaining bids will

be returned to the bidders unopened. The responsive Bidders' names, the Bid prices, the total amount of each Bid, any discounts, Bid Modifications and withdrawals, and such other details as the Employer may consider appropriate, will be announced by the Employer at the opening. Any Bid price or discount, which is not read out and recorded, will not be taken in to account in Bid Evaluation.

- 23.7 In case bids are invited in more than one package, the order for opening of the "Financial Bid" shall be that in which they appear in the "Invitation for Bid".
- 23.8 The Employer shall prepare minutes of the Bid opening, including the information disclosed to those present in accordance with Sub-Clause 23.6.

24. Process to be Confidential

- 24.1 Information relating to the examination, clarification, evaluation and comparison of Bids and recommendations for the award of a contract shall not be disclosed to Bidders or any other persons not officially concerned with such process until the award of the successful Bidders has been announced. Any effort by Bidder to influence the Employer's processing of Bids or award decisions may result in the rejection of his Bid.

25. Clarification of Financial Bids

- 25.1 To assist in the examination, evaluation and comparison of Bids, the Employer may, at his discretion, ask any Bidder for clarification of his Bid, including breakdown of unit rates. The request for clarification and the response shall be in writing or by cable, but no change in the price or substance of the Bid shall be sought, offered or permitted except as required to confirm the correction of arithmetic errors discovered by the Employer in the evaluation of the Bids in accordance with Clause 27.
- 25.2 Subject to sub-clause 25.1, no Bidder shall contact the Employer on any matter relating to his bid from the time of the bid opening to the time of the contract is awarded. If the Bidder wishes to bring additional information to the notice of the Employer, it should be do so in writing.
- 25.3 Any effort by the Bidder to influence the Employer in the Employer's Bid evaluation, bid comparison or contract award decisions may result in the rejection of the Bidder's bid.

26. Examination of Bids and Determination of Responsiveness

- 26.1 During the detailed evaluation of "Technical Bids", the Employer will determine whether each Bid (a) meets the eligibility criteria defined in Clause 3 and 4, (b) has been properly signed; (c) is accompanied by the required securities and (d) substantially responsive to the requirement of the Bidding documents. During the detailed evaluation of the "Financial Bid", the responsiveness of the bids will be further determined with respect to the remaining bid conditions i.e., priced Bill of Quantities, Technical specifications, and Drawings.
- 26.2 A substantially responsive "Financial Bid" is one which conforms to all the terms, conditions, and specifications of the Bidding documents, with out material deviation or reservation. A material deviation is one **(a)** which affects in any substantial way the scope, quality, or performance of the works; **(b)** which limits in any substantial way, in consistent with the bidding documents, the Employer's rights or the bidder's obligations under the contract; or **(c)** whose rectification would affect unfairly the competitive position of other Bidders presenting substantially responsive Bids.
- 26.3 If a "Financial Bid" is not substantially responsive, it will be rejected by the Employer, and may not subsequently be made responsive by correction or withdrawal of the non-conforming deviation or reservation.

27. Correction of Errors

27.1 “Financial Bids” determined to be substantially responsive will be checked by the Employer for any arithmetic errors. Errors will be corrected by the Employer as follows:

- (a) Where there is discrepancy between the rates in figures and in words, the rate in words will govern; and
- (b) Where there is discrepancy between the unit rate and the line item total resulting from multiplying the unit rate by the quantity, the unit rate as quoted will govern.

27.2 The amount stated in the “Financial Bid” will be corrected by the Employer in accordance with the above procedure and the Bid amount adjusted with the concurrence of the Bidder in the following manner.

- (a) If the Bid price increases as a result these corrections, the amount as stated in the bid will be the “Bid Price” and the increase will be treated as rebate;
- (b) If the Bid price decreases as a result of the corrections, the decreased amount will be treated as “bid price”.

Such adjusted bid price shall be considered as binding upon the Bidder. If the Bidder does not accept the corrected amount the Bid will be rejected, and the Bid security may be forfeited in accordance with Sub-Clause 16.6 (b).

28. Deleted.

29. Evaluation and Comparison of Financial Bids.

29.1 The Employer will evaluate and compare only the Bids determined to be substantially responsive in accordance with Sub-Clause 26.2.

29.2 In evaluating the Bids, the Employer will determine for each Bid the evaluated Bid price by adjusting the Bid price as follows:

- (a) Making any correction for errors pursuant to Clause 27; or
- (b) Making an appropriate adjustment for any other acceptable variations, deviation; and
- (c) Making appropriate adjustments to reflect discounts or other price modifications offered in accordance with Sub-Clause 23.6.

29.3.1 The Employer reserves the right to accept or reject any variation or deviation. Variations and deviations and other factors, which are in excess of requirements of the Bidding documents or otherwise result in unsolicited benefits for the Employer shall not be taken into account in Bid evaluation.

29.4 The estimated effect of the price adjustment conditions under Clause 47 of the *Conditions of Contract*, during the period of implementation of the contract, will not be taken into account in Bid evaluation.

29.5 If the Bid of the successful Bidder is seriously unbalanced in relation to the Engineer’s estimate of the cost of work to be performed under contract, the Employer may require the bidder to produce detailed price analysis for any or all items of the Bill of Quantities, to demonstrate the internal consistency of those prices with the construction methods and schedule proposed. After evaluation of the price analysis, the Employer may require that amount of the performance security set forth in Clause 34 be increased at the expense of the successful Bidder to a level sufficient to protect the Employer against financial loss in the event of default of the successful Bidder under the Contract.

29.6 A Bid, which contains several items in the Bill of Quantities which are unrealistically priced low and which cannot be substantiated satisfactorily by the Bidder, may be rejected as non-responsive.

30. Deleted.**F. AWARD OF CONTRACT.****31. Award Criteria.**

31.1 Subject to Clause 32, the Employer will award the contract to the bidder whose Bid has been determined.

- (i) To be substantially responsive to the Bidding documents and who has offered the lowest evaluated Bid price; and
- (ii) To be within the available bid capacity adjusted to account for his bid price which is evaluated the lowest in any of the packages opened earlier than the one under consideration.

In no case, the contract shall be awarded to any bidder whose available bid capacity is less than the evaluated bid price, even if the said bid is lowest evaluated bid. The contract will in such cases be awarded to the next lowest bidders at his evaluated bid price.

32. Employer's Right to Accept any Bid and to Reject any of all Bids.

32.1 Notwithstanding Clause 31, the Employer reserves the right to accept or reject any Bid, and to cancel the Bidding process and reject all Bids, at any time prior to the award of Contract, without thereby incurring any liability to the affected Bidder or Bidders or any obligation to inform the affected Bidder or Bidders of the grounds for the Employer's action.

33. Notification of Award and Signing of Agreement.

33.1 The Bidder whose Bid has been accepted will be notified of the award by the Employer prior to expiration of the Bid validity period by cable, telex or facsimile confirmed by registered letter. This letter (hereinafter and in the Conditions of Contract called the "Letter of Acceptance") will state the sum that the Employer will pay the Contractor in consideration of the execution, completion and maintenance of the Works by the contractor as prescribed by the contract (hereinafter and in the contract called the "Contract Price").

33.2 The notification of award will constitute the formation of the Contract, subject only to the furnishing of a performance security in accordance with provision of Clause 34.

33.3 The Agreement will incorporate all agreement between the Employer and the successful Bidder. The successful bidders will furnish performance security and sign the agreement within 2 (two) weeks following the notification of award (letter of acceptance).

33.4 Upon the furnishing by the successful Bidder of the performance security, the Employer will promptly notify the other bidders that their Bids have been unsuccessful.

34. Performance Security.

34.1 Within 2 (two) weeks of issue of the Letter of Acceptance, the successful Bidder shall deliver to the Executive Engineer, Tezu Division, PWD, Tezu a performance security in any of the forms given below for an amount equivalent to 5% of the Contract price plus additional security of unbalance bids in accordance with Clause 29.5 of ITB and Clause 52 of conditions of Contract.

- a bank guarantee in the form given in section 8; or
- Certified Cheque/ Bank Draft as indicated in Appendix

34.2 If the performance security if provided by the successful bidder in the form of a bank Guarantee, it shall be issued either (a) at the bidders option, by a Nationalized/Schedule Indian Bank or (b) by a foreign bank located in India and acceptable to the Employer.

34.3 Failure of the successful bidder to comply with the requirements of Sub-Clause 34.1 shall constitute sufficient grounds for cancellation of the award and forfeiture of the bid security.

35. Advance payment and security. (Not Applicable)

35.1 ~~The Employer will provide an advance payment on the contract price as stipulated in the conditions of contract, subject to maximum amount, as stated in the contract data.~~

36. Dispute Review Expert.

36.1 The Employer proposes that name of the proposed Dispute Review Expert as indicated in Appendix be appointed as Dispute Review Expert under the Contract, at a daily fee as indicated in Appendix plus reimbursable expenses. If the Bidder disagrees with this proposal, the Bidder should so state in the Bid. If the Letter of Acceptance, the Employer has not agreed on the appointment of the Dispute Review Expert, the dispute review expert shall be appointed by the council of Indian Roads Congress at the request of either party.

37. Corrupt or Fraudulent Practices.

37.1 The Employer will reject a proposal for award if it determines that the bidder recommended for award has engaged in corrupt or fraudulent practices in competing for the contract in question will declare the form in eligible, either indefinitely or for a stated period of time, to be awarded a contract with National Highway Authority of India/State P.W.D. and any other agencies, if at any time determines that the firm has engaged in corrupt or fraudulent practices in competing for the contractor, or in execution.

37.2 Further more; Bidder shall be aware of the provision stated in Sub-Clause 23.2 and Sub-Clause 59.2 of the Conditions of Contract.

APPENDIX to ITB**Clause Reference
with respect to
Section-I.**

1. Name of the Employer is Chief Engineer, Eastern Zone, PWD, Namsai. [C1.1.1]
2. The Last five years
 - 2017 - 2018
 - 2018 - 2019
 - 2019 - 2020
 - 2020 - 2021
 - 2021 - 2022
3. The annual financial turn over amount is Rs. 1756.00 lakhs (Rupees Seventeen Crores fifty six lakhs only) [C1.4.5.3(a)]
4. Value of work done is Rs. 1756.00 lakhs (Rupees Seventeen Crores fifty Six Lakhs) only for three similar works, Rs. 2634.00 lakhs (Rupees Twenty six Crores thirty four Lakhs) only for two similar works and Rs. 3512.00 lakhs (Rupees Thirty five Crores Twelve Lakhs) only for one similar work. [C1.4.5.3(b)]
5. Liquid assets and/or availability of credit facilities is is Rs. 439.00 lakhs (Rupees Four Crores Thirty nine Lakhs) only. [C1.4.5.6]
6. Price level of the financial year **2022-23** [C1.4.5.2]
7. The pre-bid meeting will take place at Office of the Executive Engineer, Tezu Division, PWD, Tezu on 02/01/2023 at 1100 Hrs. [C1.9.2.1]
8. Address of the Employer: **Chief Engineer (EZ), PWD, AP, Namsai, Pin-792103**
9. Identification:
 - Bid for **“Construction of C.C. road in Tezu Township”**
 - Bid reference No. TDW/NIT-15/SPA/2022-23/03/1956-63 Dated 08/12/2022 (insert number)
 - Electronic Tender No.....
 - Do not open before (time and date)
10. The bid should be submitted online latest by **1100 hrs on 04/01/2023** [C1.20]

11. The technical bid will be opened at **Office of the Executive Engineer, Tezu Division, PWD, Tezu at 1530 hrs on 04/01/2023.** [C1.23.1]
12. The Bid Security in favour of **Executive Engineer, Tezu Division, PWD, AP, Tezu,** payable at SBI, Tezu Branch (C1.16)
13. The name of Dispute Review Expert **will be decided later through IRC, New Delhi mutual discussion with successful bidder** [C1.36.1]
14. Escalation factors (for the cost of works executed and financial figure to a common base value for works completed) [C1.4.5.2]

<u>Year Before</u>	<u>Multiply factor</u>
One	1.1
Two	1.21
Three	1.33
Four	1.46
Five	1.61

ANNEXURE-I**Minimum Key Personnel for the project**

[Reference Cl. 4.5.4]

Sl No.	Minimum Qualification of Technical Representative	Discipline	Designation	Minimum Experience	Number	Rate at which recovery shall be made per month per person from the contractor in the event of not fulfilling provision of clause 36(i)	
						Figures	Words
1	Graduate Engineer	Civil	Project Manager	20 Years (And having experience of one similar nature of work)	1	Rs. 60,000.00	(Rupees sixty thousand) only
2	Graduate Engineer	Civil	Deputy Project Manager	12 Years (And having experience of one similar nature of work)	1	Rs. 40,000.00	(Rupees forty thousand) only
3	Graduate Engineer or Diploma Engineer	Civil	Project / Site Engineer	5 years or 10 years respectively.	2	Rs. 25,000.00	(Rupees twenty five thousand) only
4	Graduate Engineer or Diploma Engineer	Civil	Project Planning / Quality / Billing Engineer	2 years or 5 years respectively.	2	Rs. 15,000.00	(Rupees fifteen thousand) only

List of Plant & Equipment to be deployed on Contract Work

[Reference Cl. 4.5.5]

Sl.No.	Type of equipment	Maximum age on the date of opening of bids (in years)	Minimum requirements	Remarks
1	2	3	4	5
1	Embankment construction			
	i) Tractor with ripper attachment	5	3	
	ii) Three wheel static roller	5	3	
	iii) Hydraulic excavator 1 cum bucket capacity	5	3	
2	Dry lean concrete sub-base			
	i) Vibratory roller 8-10 tonne capacity	5	3	
	ii) Plate compactor	5	5	
	iii) Liquid curing compound sprayer	5	10	
	iv) Gunny bag/Hessian cloth/Coir felt		As required	
	v) Scabbler for correction surface regularity	5	2	
	vi) Leveling instrument	5	2	
3	Paving quality concrete and DLC			
	i) Cement concrete batch mix plant @ 75 cum/hour	5	5	
	ii) Tipper/dumper 5 cum capacity	5	4	
	iii) Slip form paver with electronic sensor	5	1	
	iv) Road sweeper @ 15250 sqm/hour	5	2	
	v) Front end loader 1 cum bucket capacity	5	2	
	vi) Electric generator 250 KVA	5	2	
	vii) Water tanker 6 KL capacity	5	2	
	viii) Transits truck agitator 5 cum capacity	5	2	
	ix) Joint cutting machine (Concrete saw)	5	5	
	x) Dowel bar inserter (DBI)	5	5	
	xi) Dowel cradles/chair for manual dowel placement		As required	
	xii) Steel bulk-heads	5	5	
	xiii) Tie bar supporting assembly or automatic tie bar inserter.	5	5	
4	Finishing operation – Surface and Joints			

	i) Wooden bridges ii) Floats (Longitudinal and long handled wooden floats). iii) Templates iv) Three-metre long straight edge including one master straight edge. v) Graduated wedge. vi) Mild steel sections and blocks for making joint grooves. vii) Edging tools including double-edging tools. viii) Canvas belts ix) Long handled brooms x) Saw-cutting machines xi) Scabbler (for grinding local high spots)	5 to 7 years for all	As required	
5	Cleaning and Sealing Joints			
	i) Iron raker ii) Coir brush iii) Cycle pump/pneumatic air blower/air compressor iv) Kerosene stove v) Thermometer vi) Transferring pot vii) Double Jacketed melter viii) Painter's brush ix) Pouring kettle x) Scraper xi) Sand paper/sand blasting equipment xii) Plywood planks to keep on both sides of the joint groove. xiii) Gun for placing polysulphide	5 to 7 years for all	As required	
6	Steel shuttering	5	2000 sqm	
7	Steel props	5	3000 cum	
8	Needle vibrator	5	4 Nos.	

Note :-

- 1) Tools and Plants not mentioned above but need of which may arise during the course of execution shall be arranged by the contractor as directed by the Engineer-in-Charge.
- 2) The requirement of each item of Tool and Plant may be more than what has been indicated above. Shortfalls, if any shall be arranged by the contractor as directed by the Engineer-in-Charge.

List of In-situ testing equipments to be provided by the Contractor at site Lab.

Sl.No.	Name of equipment	Qty	Remarks
1	2	3	4
1	Set of IS sieves of all sizes both for coarse and fine aggregate (2 set of coarse and 2 set for fine aggregate)	10 Set	
2	Standard proctor Apparatus	10 Set	
3	Attenbarg limit liquid limit apparatus	10 Set	
4	Attenbarg limit plastic limit apparatus	10 Set	
5	Auto Compaction	10 Set	
6	Rapid Moisture meter	10 Set	
7	Moisture container	10 Set	
8	Agg. Impact value machine with accessories	10 Set	
9	3 m straight edge with wedge	10 Set	
10	Water Bath (Thermostatically controller upto 600°C)	10 Set	
11	Softening Test Apparatus	10 Set	
12	Sand replacement Apparatus	10 Set	
13	Core cutter with collar & hand hammer	10 Set	
14	Electronic Balance (200 Gms-5 Kg)	10 Set	
15	Concrete Cube mould 7.06 cm x 7.06	100 Nos.	
16	Concrete Mould (150x150x150 mm)	15 Nos.	
17	Concrete Mould (50x50x50 mm)	15 Nos.	
18	Motar Mould (70.6 x 70.6 x 70.6 mm)	15 Nos.	
19	Marshal stability Testing Machine	4 Nos.	
20	500 KN electrically cum hand operated compressive Testing Machine.	4 Nos.	

Note :- The above list not exhaustive. Any other/additional testing equipment which may be necessary as per standard practice for quality control and assurance may be arranged as directed by the Engineer-in-Charge.

BLANK

SECTION – 2
QUALIFICATION INFORMATION

BLANK

QUALIFICATION INFORMATION

The information to be filled in by the Bidder in the following pages will be used for purposes of post qualification as provided for in Clause 4 of the Instructions to Bidders. This information will be incorporated in the Contract.

1. For Individual Bidders

1.1 Constitution or legal status of Bidder

[Attach copy]

Place of registration/incorporation

Principal place of business:

Power of attorney of signatory of Bid

[Attach]

1.2 Total value of Civil Engineering construction

Work performed in the last five years*

(Rs. in Lakhs)

2017-18

2018-19

2019-20

2020-21

2021-22

β

1.3.1 Work performed as prime contractor, work performed in the past as a nominated sub-contractor will also be considered provided the sub-contract involved execution of all the main items of work described in the bid document, provided further that all other qualification criteria are satisfied (in the same name) of works of a similar nature over the last five years. **

Project Name	Name of the Employer*	Description of the work	Contract No. & Date.	Value of contract (Rs.in Crore)	Date of issue of work order	Stipulated period of completion	Actual date of completion*	Remarks explaining reasons for delay & work completed

*Attach certificates (s) from the Engineer(s)-in Charge

**Immediately preceding the financial year in which bids are received.

β Attach certificate from Chartered Accountant

- 1.3.2 Quantities of work executed as prime contractor, work performed in the past as a nominated sub-contractor will also be considered provided the sub-contract involved execution of all main items of work described in the bid document, provided further that all other qualification criteria are satisfied (in the same name and style) in the five years.**

Year	Name Of Work	Name of the Employer*	Quantity of work performed @					Remarks* (indicate contract reference)
			E/W (cum)	GSB (cum)	WBM (Cum)	BT (cum)	CC Works (Cum)	
			NOT APPLICABLE.					

- 1.4 **Information on Bid Capacity** (works for which bids have been submitted and works which are yet to be completed) as on the date of this bid.

(A) Existing commitments and on-going works:

Description Of works	Place & State	Contract No. & Date.	Name & Address Of Employer	Value of Contract (Rs. Crore)	Stipulated Period of Completion	Value of Works* remaining to be completed (Rs. Cr.)	Anticipated Date of Completion
1	2	3	4	5	6	7	8

Total =

*Attach certificate(s) from the Engineer (s)-in-charge.

**Immediately preceding the financial year in which bids are received.

(B) Works for which bids already submitted:

Description Of Works	Place & State	Name & Address of Employer	Estimated vale of work (Rs. Crore)	Stipulated period of completion	Date when decision is expected	Remarks, if any
1	2	3	4	5	6	7

1.5 **Availability of key items of contractor's Equipment essential for carrying out the works** [Ref. Clause 4.5.5]. The Bidder should list all the information requested below. Refer also to Sub Clause 4.3 (d) of the Instructions to Bidders.

Type of Equipment	Requirement		Availability proposals			Remarks
	No.	Capacity	*Owned	Nos. Capacity	Age/ Condition	

NOTE: All the Construction machineries, Tools and Plants shall be in the name of the respective bidders in support of which the bidder shall upload ownership documents, failing which the bid shall be rejected. No hire/lease of any construction machineries shall be accepted. The Registration Certificate & Insurance of all machineries submitted by the bidders shall be scrutinized through online verification system.

1.6 **Qualifications and experience of key personnel required for administration and execution of the Contract** [Ref. Clauses 4.5.4]. Attach biographical data. Refer also to Sub Clause 4.3 (e) of instructions to Bidders and Sub Clause 9.1 of the Conditions of Contract.

Position	Name	Qualification	Total Experience (Year)	In similar Works (Year)	Years of experience in the proposed position
Project Manager					
Site Engineer					
Plant Engineer					
Soil & Material Engineer					

1.7 **Proposed sub-contracts and firms involved** [refer ITB Clause 4.3(k)]

Sections of the works	Value of Sub-Contract	Sub-contractor (Name & Address)	Experience in Similar work

1.8 **Financial reports for the last five years:** balance sheets, profit and loss statements, auditors’ reports (in case of companies/corporation), etc. List them below and attach copies.

1.9 **Evidence of access to financial resources to meet the qualification requirements:** cash in hand, lines of credit, etc. List them below and attach copies of support documents.

1.10 Name, Address, and Telephone, telex, and fax numbers of the Bidders’ bankers who may provide references if contacted by the Employer.

1.11 **Information on litigation history in which the Bidder is involved.**

Other Party (ies)	Employer	Cause of Dispute	Amount involved	Remarks showing present status

1.12 Statement of compliance under the requirements of Sub Clause 3.2 of the instructions to Bidders (name of Consultant engaged for project preparation is)

1.13 Proposed work method and schedule. The Bidder should attach descriptions, drawings and charts as necessary to comply with the requirements of the Bidding documents. [Refer ITB Clause 4.1 & 4.3 (1)]

1.14 Programme.

1.15 Quality Assurance Programme.

2. Deleted

3. Additional Requirements

3.1 Bidders should provide any additional information required to fulfill the requirements of Clause 4 of the Instructions to the Bidders, if applicable

- (i) Legal document in the form of Affidavit
- (ii) Undertaking
- (iii) Authority to seek reference from the bidders' bankers

SAMPLE FORMAT FOR EVIDENCE OF ACCESS TO OR
AVAILABILITY OF CREDIT FACILITIES

BANK CERTIFICATE

This is to certify that M/s. _____ is a reputed Company with a good financial standing.

It the contract for the work, namely _____ is awarded to the above firm, we shall be able to provide overdraft/ credit facilities to the extent of Rs. _____ to meet their working capital requirements for executing the above contract during the contract period.

(Signature)
Name of Bank
Senior Bank Manager
Address of the Bank

AFFIDAVIT.

1. I, the undersigned, do hereby certify that all the statements/information furnished in the bid document for the work of _____ (name of work) are true and correct to the best of my knowledge.
2. The undersigned/the undersigned on behalf of the Firm/Company also hereby certify that neither I/our Firm/Company have abandoned any work in India nor any contract awarded to us for such works have been rescinded, during last five years prior to the date of this bid.
3. The undersigned hereby authorize(s) and requests) any Bank, Person, Firm or Corporation to furnish pertinent information deemed necessary and requested by the department to verify the statements/information or regarding my (our) competence and general reputation.
4. The undersigned understand and agrees that further qualifying information may be requested, and agrees to furnish any such information at the request of the Department/project implementing agency.

(Signature of the Bidder with proper title and full address)

Date

UNDERTAKING

I, The undersigned do hereby undertake that our firm M/s. _____
_____ would invest a minimum cash up to 25% of the value of the
work during implementation of the Contract and provide the service and facilities as per clause 9 & 10 of
the Additional Special Conditions.

(Signed by an Authorized Officer of the Firm)

Title of Officer

Name of Firm

Date

UNDERTAKING FOR BID VALIDITY

Bid for the work: -**“Construction of C.C. road in Tezu Township” (BID No: TDW/NIT-15/SPA/2022-23/03)**

An undertaking is hereby given that the bid submitted by me /us for the aforesaid work shall remain valid up to _____

Date:-

Signature of the bidder

Name in full(in block capital letters)

Address-

Place:-

ACCEPTANCE/NON ACCEPTANCE OF DISPUTE REVIEW EXPERT PROPOSED IN CLAUSE 36.1

I/We accept appointment of Sri.....as the Dispute Review Expert.

(OR)

I/We do not accept appointment of Sri.....as the Dispute Review Expert and propose instead that Sri.....to be appointed as the Dispute Review Expert.

Date:-

Signature of the bidder
Name in full(in block capital letters)
Address-

Place:-

AUTHORITY

Employer (therein after called the Chief Engineer, Eastern Zone, PWD) is hereby authorized to seek reference from my Banker, as and when required.

Date:-

Signature of the bidder
Name in full(in block capital letters)
Address-

Place:-

Name & address of the Banker
with contact Telephone No./FAX No.

BLANK

SECTION – 3
CONDITIONS OF CONTRACT

BLANK

CONDITIONS OF CONTRACT

Table of Contents

A. General

1. Definitions
 2. Interpretation
 3. Language and Law
 4. Engineer's Decisions
 5. Delegation
 6. Communications
 7. Sub-contracting
 8. Other contractors
 9. Personnel
 10. Employer's & Contractor Risks
 11. Employer's Risks
 12. Contractor's Risks
 13. Insurance
 14. Site Investigation Report
 15. Queries about the Contract Data
 16. Contractor to Construct the Works
 17. The Works to be completed by the Intended Completion Date
 18. Approval by the Engineer
 19. Safety
 20. Discoveries
 21. Possession of the Site
 22. Access to the site
 23. Instructions
 24. Disputes
 25. Procedures for Disputes
 26. Replacement of Dispute Review Expert
- #### B. Time Control
27. Programme
 28. Extension of the Intended Completion Date
 29. Deleted
 30. Delays ordered by the Engineer
 31. Management Meeting
 32. Early Warning

C. Quality Control

33. Identifying Defects
34. Tests
35. Correction of Defects
36. Uncorrected Defects

D. Cost Control

37. Bill of Quantity
38. Changes in the Quantities
39. Variations
40. Payments and variations
41. Cash Flow Forecasts
42. Payment Certificates
43. Payments
44. Compensation Events
45. Tax
46. Currencies
47. Price Adjustment
48. Retention
49. Liquidated Damages
50. Deleted
51. Advance Payment
52. Securities
53. Deleted
54. Cost of Repairs

E. Finishing the Contract

55. Completion
56. Taking Over
57. Final Account
58. Operating and Maintenance Manuals
59. Termination
60. Payment upon Termination
61. Property
62. Release from Performance

F. Special Conditions of Contract

G. Additional Condition

H. Additional Special Condition

CONDITIONS OF CONTRACT

A. GENERAL

1. Definitions

- 1.1 Terms, which are defined in the Contract Data, are not also defined in the Conditions of Contract but keep their defined meanings. Capital initials are used to identify defined terms.

The **Adjudicator** (synonymous with Dispute Review Expert) is the person appointed jointly by the Employer and the Contractor to resolve disputes in first instance, as provided for in Clauses 24 and 25. The name of the Adjudicator is defined in the Contract Data.

Bill of Quantities means the priced and completed Bill of Quantities forming part of the Bid.

Compensation Events are those defined in Clause 44 hereunder.

The **Completion Date** is the date of completion of the works as certified by the Engineer in accordance with Sub-Clause 55.1.

The **Contract** is the contract between the Employer and the Contractor to execute, complete and maintain the Works till the completion of Defects Liability Period. It consists of the documents listed in Clause 2.3 below.

The **Contract Data** defines the documents and other information, which comprise the Contract.

The **Contractor** is a person or corporate body whose Bid to carry out the Works has been accepted by the Employer.

The **Contractor's Bid** is the completed bidding document submitted by the contractor to the Employer and includes Technical and Financial Bids.

The **Contract Price** is the price stated in the Letter of Acceptance and thereafter as adjusted in accordance with the provisions of the Contract.

Days are calendar days; Months are Calendar months.

A **Defect** is any part of the Works not completed in accordance with the Contract.

The **Defects Liability Period** is the period named in the Contract Data and calculated from the Completion Date.

The **Employer** is the party who will employ the Contractor to carry out the Works.

The **Engineer** is the person names in the Contract Data (or any other competent person appointed and notified to the Contractor to act in replacement of the Engineer) who is responsible for supervising the Contractor, administering the contract, certifying payments due to the Contractor, issuing and valuing Variation to the Contract, awarding extensions of time, and valuing Compensation Events.

Equipment is the Contractor's machinery and vehicles brought temporarily to the Site to construct the Works.

The **Initial Contract Price** is the Contract price listed in the Employer's Letter of Acceptance.

The **Intended Completion Date** is the date on which it is intended that the Contractor shall complete the Works. The Intended Completion Date is specified in the Contract Data.

The Intended Completion Date may be revised only by the Engineer by issuing and extension of time.

Materials are all supplies, including consumables, used by the contractor for incorporation in the Works.

Plant is any integral part of the works, which is to have a mechanical, Electrical, Electronic or Chemical or Biological function.

The **Site** is the area defined as such in the Contract Data.

Site Investigation Reports are those, which were included in the bidding documents and are factual interpretative reports about the surface and sub-surface conditions at the site.

Specification means the specifications of the works included in the contract and any modification or addition made or approved by the Engineer.

The Start Date is given in the Contract data. It is the date when the contractor shall commence execution of the works. It does not necessarily coincide with any of the Site Possession Dates.

A Sub-Contractor is a person or corporate body who has a contract with the Contractor to carry out a part work in the contract, which includes work on the site.

Temporary works are works designed, constructed, installed, and removed by the Contractor, which are needed for construction or installation of the works.

A Variation is an instruction given by the Engineer, which varies the works.

The **Works are** what the contract requires the contractor to construct, install, and turn over to the Employer, as defined in the contract data.

2. Interpretation.

- 2.1 In interpreting these conditions of contract, singular also means plurals, male also means female or neuter, and the other way around. Headings have no significance. Words have their normal meaning under the language of the contract unless specially defined. The Engineer will provide instructions clarifying queries about the conditions of the contract.
- 2.2 If sectional completion is specified in the Contract Data, references in the conditions of contract to the works, the completion date, and the intended completion date apply to any section of the works (other than references to the completion date and intended completion date for the whole of the works).
- 2.3 The documents forming the Contract shall be interpreted in the following order of priority:
 - (1) Agreement
 - (2) Letter of Acceptance, notice to proceed with the works
 - (3) Contractor's Bid
 - (4) Contract Data
 - (5) Condition of Contract including Special Conditions of Contract
 - (6) Specifications
 - (7) Drawings (if furnished to the bidder in the set of bid document issued).
 - (8) Bill of Quantities and
 - (9) Any other document listed in the Contract Data as forming part of the Contract

3. Languages and Law.

3.1 The language of the Contract and the law governing the Contract are stated in the Contract Data.

4. Engineer's Decisions.

4.1 Except where otherwise specifically stated, the Engineer will decide contractual matters between the Employer and the Contractor in role representing the Employer.

5. Delegation.

5.1 The Engineer may delegate any of his duties and responsibilities to other people except to the Adjudicator after notifying the Contract and may cancel any delegation after notifying the contractor.

6. Communications.

6.1 Communications between parties which are referred to in the conditions are effective only when in writing. A notice shall be effective only when it is delivered (in terms of Indian Contract Act).

7. Sub-Contracting. (Not Applicable)

7.1 The Contractor may Sub-Contract any portion of work, up to a limit specified in Contract Data, with the approval of the Engineer in writing. Sub-Contracting does not alter the Contractor's obligations.

8. Other Contractors.

8.1 The Contractor shall co-operate and share the site with other contractors, public authorities, utilities and the Employer between the dates given in the schedule of other contractors. The Contractor shall as referred to in the contract data, also provide facilities and services for them as described in the schedule. The Employer may modify the schedule of other contractors and shall notify the contractor of any such modification.

9. Personnel.

The Contractor shall employ the Key Personnel named in the Schedule of Key Personnel as referred to in the Contract Data to carry out the function stated in the schedule or other personnel approved by the Engineer. The Engineer will approve any proposed replacement of Key Personnel only if their qualifications, abilities and relevant experience are substantially equal to or better than those of the personnel listed in the schedule.

9.2 If the Engineer ask the Contractor to remove a person who is a member of the contractor's staff or his work force stating the reasons the contractor shall ensure that the person leaves the site within 7 days and has no further connection with work in the Contract.

10. Employer's and Contractor's Risks.

10.1 The Employer carries the risks which this contract states are Employer's risks and the Contractor carries the risks which this contract states are contractor's risks.

11. Employer's Risks.

11.1 The Employer is responsible for the excepted risks which are (a) in so far as they directly affect the execution of the works in India, the risks of War, hostilities, invasion, act of foreign enemies, rebellion, revolution, insurrection or military or usurped power, civil work, riot commotion or disorder (unless restricted to the contractor's employees) and contamination from any nuclear fuel or nuclear waste or radioactive toxic explosive or (b) a cause due solely to the design of the works, other than the contractor's design.

12. Contractor's Risks

- 12.1 All risks of loss of or damage to physical property and of personnel injury and death which arise during and in consequence of the performance of the contract other than the expected risks are the responsibility of the contractor.

13. Insurance

- 13.1 The Contractor shall provide in the joint names of the Employer and the Contractor, insurance covered from the Start Date to the end of the Defects Liability Period in the amounts and deductibles stated in contract data for the following events which are due to the contractor's risks:

- (a) Loss of or damage to the Works, Plant and Materials;
- (b) Loss of or damage to Equipment;
- (c) Loss of or damage of property (except the Works, Plant, Materials and Equipment) in connection with the Contract; and
- (d) Personal injury or death.

- 13.2 Policies and certificates for insurance shall be delivered by the Contractor to the Engineer for the Engineer's approval before the Start Date. All such insurance shall provide for compensation to be payable in the types and proportions of currencies required to rectify the loss or damage incurred.

- 13.3 If the Contractor does not provide any of the policies and certificates required, the Employer may effect the insurance which the Contractor should have provide and recover the premiums the Employer has paid from payments otherwise due to the Contractor or, if no payment is due, the payment of the premiums shall be a debt due.

- 13.4 Alterations to the terms of insurance shall not be made without the approval of the Engineer.

- 13.5 Both parties shall comply with any conditions of the insurance policies.

14. Site Investigation Reports

- 14.1 The Contractor, in preparing the Bid, shall rely on any site Investigation Reports referred to in the Contract Data, supplemented by any information available to the Bidder.

15. Queries about the Contract Data

- 15.1 The Engineer will clarify queries on the Contract Data.

16. Contractor to Construct the Works

- 16.1 The Contractor shall construct and install the Works in accordance with the Specification and Drawings.

17. The Works to be completed by the Intended Completion Date.

- 17.1 The Contractor may commence execution of the Works on the Start Date and shall carry out the Works in accordance with the programme submitted by the Contractor, as updated with the approval of the Engineer, and complete them by the Intended Completion Date.

18. Approval by the Engineer

- 18.1 The Contractor shall submit Specifications and Drawings showing the proposed Temporary Works to the Engineer, who is to approve them if they comply with the Specifications and Drawings.
- 18.2 The Contractor shall be responsible for design of temporary works.
- 18.3 The Engineer's approval shall not alter the Contractor's responsibility for design of the Temporary Works.
- 18.4 The Contractor shall obtain approval of third parties to design of the Temporary Works where required.
- 18.5 All Drawings prepared by the Contractor for the execution of the temporary or permanent Works, are subject to prior approval by the Engineer before their use.

19. Safety

- 19.1 The Contractor shall be responsible for the safety of all activities on the site.

20. Discoveries

- 20.1 Anything of historical or other interest or of significant value unexpectedly discovered on the Site is the property of the Employer. The Contractor is to notify the Engineer of such discoveries and carry out the Engineer's instructions for dealing with them.

21. Possession of the Site

- 21.1 The Employer shall give possession of all parts of the Site to the Contractor. If the possession of a part is not given by the date stated in the Contract Data the Employer is deemed to have delayed the start of the relevant activities and this will be Compensation Event.

22. Access to the Site

- 22.1 The Contractor shall allow the Engineer and any person authorized by the Engineer access to the Site, to any place where work in connection with the Contract is being carried out or is intended to be carried out and to any place where materials or plant are being manufactured/fabricated/assembled for the works.

23. Instructions

- 23.1 The Contractor shall carry out all instructions of the Engineer pertaining to works, which comply with the applicable laws where the Site is located.
- 23.2 The Contractor shall permit the Employer to inspect the Contractor's accounts and records relating to the performance of the Contractor and to have them audited by auditors appointed by the Employer, if so required by the Employer.

24. Disputes

- 24.1 If the Contractor believes that a decision taken by the Engineer was either outside the authority given to the Engineer by the Contract or that the decision was wrongly taken, the decision shall be referred to the Dispute Review Expert within 14 days of the notification of the Engineer's decision.

25. Procedure for Disputes

- 25.1 The Dispute Review Expert (Board)* shall give a decision in writing within 28 days of receipt of a notification of a dispute.

- 25.2 The Dispute Review Expert (Board)* shall be paid daily at the rate specified in the Contract Data together with reimbursement expenses of the types specified in the Contract Data and the cost shall be divided equally between the Employer and the Contractor, whatever decision is reached by the Dispute Review Expert. Either party may give notice to the other to refer a decision of the Dispute Review Expert to an Arbitrator within 28 days of the Dispute Review expert's written decision. If neither party refers the dispute to arbitration within the next 28 days, the Dispute Review Expert's decision will be final and binding.

*Dispute Review Expert to be provided for works costing up to Rs. 50 Crores. Dispute Review Board of three members (one from Employer, one from Contractor and one to be nominated by IRC Council and agree by the representative members of Employer and Contractor) for works costing more than Rs. 50 Crores.

- 25.3 The arbitration shall be conducted in accordance with the arbitration procedure started in the Special Conditions of Contract.

26. Replacement of Dispute Review Expert.

- 26.1.1 Should the Dispute Review Expert resign or die, or should the Employer and the Contractor agree that the Dispute Review Expert is not fulfilling his functions in accordance with the provisions of the Contract, a new Dispute Review Expert will be jointly appointed by the Employer and the Contractor. In case of disagreement between the Employer and the Contractor, within 30 days, the Dispute Review Expert shall be designated by the Appointing Authority indicated in the Contract Data at the request of either party, within 14 days of receipt of such request.

B. TIME CONTROL

27. Programme.

- 27.1 Within the time stated in the Contract Data the Contractor shall submit to the Engineer for approval a Programme showing the general methods, arrangements, order, and timing for all the activities in the works along with monthly cash flow forecast.
- 27.2 An update of the Programme shall be a programme showing the actual progress achieved on each activity and the effect of the progress achieved on the timing of the remaining work including any changes to the sequence of the activities.
- 27.3 The Contractor shall submit to the Engineer, for approval, an updated Programme at intervals no longer than the period stated in the Contract Data. If the Contractor does not submit an updated Programme within this period, the Engineer may withhold the amount stated in the Contract Data from the next payment certificate and continue to withhold this amount until the next payment after the date on which the overdue Programme has been submitted.
- 27.4 The Engineer's approval of the Programme shall not alter the Contractor's obligations. The Contractor may revise the Programme and submit it to the Engineer again at any time. A revised programme is to show the effect of variations and compensation events.

28. Extension of the Intended Completion Date

- 28.1 The Engineer shall extend the Intended Completion Date if a Compensation Event occurs or a Variation is issued which makes it impossible for completion to be achieved by the Intended Completion Date without the Contractor taking steps to accelerate the remaining work and which would cause the Contractor to incur additional cost.
- 28.2 The Engineer shall decide whether and by how much to extend the Intended Completion Date within 35 days of the Contractor asking the Engineer for a decision upon the effect of a Compensation Event or variation and submitting full supporting information. If the Contractor has failed to give early warning of a

delay or has failed to cooperate in dealing with a delay, the delay by this failure shall not be considered in assessing the new Intended Completion Date.

- 28.3 The Engineer shall within 14 days of receiving full justification from the contractor for extension of Intended Completion Date refer to the Employer his decision. The Employer shall in not more than 21 days communicate to the Engineer the acceptance or otherwise of the Engineer's decision. If the Employer fails to give his acceptance, the Engineer shall not grant the extension and the contractor may refer the matter to the Dispute Review under Clause 24.1.

29. Deleted

30. Delays ordered by the Engineer

- 30.1 The Engineer may instruct the Contractor to delay or progress of any activity within the works.

31. Management Meeting

- 31.1 Either the Engineer or the Contractor may require the other to attend a management meeting. The business of a management meeting shall be to review the plans for remaining work and to deal with matters raised in accordance with the early warning procedure.
- 31.2 The Engineer shall record the business of management meetings and is to provide copies of his record to those attending the meeting and to the Employer. The responsibility of the parties for actions to be taken is to be decided by the Engineer either at the Management meeting or after the management meeting and stated in writing to all who attended the meeting.

32. Early Warning

- 32.1 The Contractor is to warn the Engineer at the earliest opportunity of specific likely future events or circumstances that may adversely affect the quality of the work increase the Contract Price or delay the execution of works. The Engineer may require the Contractor to provide an estimate of the expected effect of the future event or circumstance on the Contract Price and Completion Date. The estimate is to be provided by the Contractor as soon as reasonably possible.
- 32.2 The Contractor shall cooperate with the Engineer in making and considering proposals for how the effect of such an event or circumstance can be avoided or reduced by anyone involved in the work and in carrying out any resulting instruction of the Engineer.

C. QUALITY CONTROL

33. Identifying Defects

- 33.1 The Engineer shall checked the Contractor's work and notify the Contractor of any defects that are found. Such checking shall not affect the Contractor's responsibilities. The Engineer may instruct the Contractor to search for a Defect to uncover and test any work that the Engineer considers may have a Defect.

34. Tests

- 34.1 If the Engineer instructs the Contractor to carry out a test not specified in the Specification to check whether any work has a Defect and the test shows that it does, the Contractor shall pay for the test and any samples. If there is no Defect the test shall be a Compensation Event.

35. Correction of Defects

- 35.1 The Engineer shall give notice to the Contractor of any Defects before the end of the Defects Liability Period, which begins at Completion and is defined in the Contract Data. The Defects Liability Period shall be extended for as long as Defects remain to be corrected.

35.2 Every time notice of a Defect is given, the Contractor shall correct the notified Defect within the length of time specified by the Engineer's notice.

36. Uncorrected Defects

36.1 If the Contractor has not corrected a Defect within the time specified in the Engineer's notice, the Engineer will assess the cost of having the Defect corrected, and the Contractor will pay this amount.

D. COST CONTROL

37. Bill of Quantities

37.1 The Bill of Quantities shall contain items for the construction, installations, testing, and commissioning work to be done by the Contractor.

37.2 The Bill of Quantities is used to calculate the Contract Price. The Contractor is paid for the quantity of the work done at the rate in the Bill of Quantities for each item.

38. Changes in the Quantities

38.1 If the final quantity of the work done differs from the quantity in the Bill of Quantities for the particular item by more than 25 per cent provided the change exceeds 1% of initial Contract Price, the Engineer shall adjust the rate to allow for the change, duly considering.

(a) Justification for rate adjustment as furnished by the contractor.

(b) Economies resulting from increase in quantities by way of reduces plant, equipment, and overhead costs,

(c) Entitlement of the contractor to compensation events where such events are caused by any additional work.

38.2 The Engineer shall not adjust rates from changes in quantities if thereby the Initial Contract Price is exceeded by more than 5 percent, except with the Prior approval of the Employer.

38.3 If requested by the Engineer, the Contractor shall provide the Engineer with a detailed cost breakdown of any rate in the Bill of Quantities.

39. Variations

39.1 All Variations shall be included in updated Programme produced by the Contractor.

40. Payments of Variations

40.1 The Contractor shall provide the Engineer with a quotation (with breakdown of unit rates) for carrying out the Variation when requested to do so by the Engineer. The Engineer shall assess the quotation, which shall be given with seven days or the request of within any longer period stated by the Engineer and before the Variations is ordered.

40.2 If the work in the Variations corresponds with an item description in the Bill of Quantities and if, in the opinion of the Engineer, the quantity of work above the limit stated in Sub-Clause 38.1 or the timing of its execution do not cause the cost per unit of quantity to change, the rate in the Bill of Quantities shall be used to calculate the value of the Variation. If the cost per unit of quantity changes, or if the nature or timing of the work in the Variation does not correspond with items in the Bill of Quantities, the quotation by the Contractor shall be in the form of new rates for the relevant items of work.

- 40.3 If the Contractor's quotation is unreasonable, the Engineer may order the Variations and make a change to the Contract Price which shall be based on Engineer's own forecast of the effects of the Variation on the Contract's costs.
- 40.4 If the Engineer decides that the urgency of varying the work would prevent a quotation being given and considered without delaying the work, no quotation shall be given and the Variation shall be treated as a Compensation Event.
- 40.5 The Contractor shall not be entitled to additional payment for costs, which could have been avoided by giving early warning.
- 41. Cash Flow Forecasts**
- 41.1 When the Programme is updated, the contractor is to provide the Engineer with an updated cash flow forecast.
- 42. Payment Certificates**
- 42.1 The contractor shall submit to the Engineer monthly statements of the estimated value of the work completed less the cumulative amount certified previously.
- 42.2 The Engineer shall check the Contractor's monthly statement within 14 days and certify the amount to be paid to the Contractor after taking into account any credit or debit for the month in question in respect of materials for the work in the relevant amounts and under conditions set forth in Sub-Clause 51(3) of the Contract Data (Secured Advance).
- 42.3 The value of work executed shall be determined by the Engineer.
- 42.4 The value of work executed shall comprise the value of the quantities of the items in the Bill of Quantities Completed.
- 42.5 The value of work executed shall include the valuation of Variations and Compensation Events.
- 42.6 The Engineer may exclude any item certified in a previous certificate or reduce the proportion of any item previously certified in any certificate in the light of later information.
- 43. Payments**
- 43.1 Payments shall be adjusted for deductions for advance payments, retention, other recoveries in terms of the contract and taxes at source, as applicable under the law. The Employer shall pay the Contractor the amounts certified by the Engineer within 28 days of the date of each certificate. If the Employer makes a late payment, the Contractor shall be paid interest on the late payment in the next payment. Interest shall be calculated from the date by which the payment should have been made up to the date when the late payment is made at 12% per annum.
- 43.2 If an amount certified is increased in a later certificate as a result of an award by the Adjudicator or an Arbitrator, the Contractor shall be paid interest upon the delayed payments as set out in this clause. Interest shall be calculated from the date upon which the increased amount would have been certified in the absence of dispute.
- 43.3 Items of the Works for which no rate or price has been entered in will not be paid for by the Employer and shall be deemed covered by other rates and prices in the Contract.
- 43.4 Whenever there is an addition or reduction to the contract price due to change in legislation, variations or on account of any other Government determined reasons amounting to more than the 25% of initial contract price, the Performance Security shall be increased/decreased by an equal percentage. The contractor shall deliver Performance Security within 21 days of receipt of request in this regard from the employer.

44. Compensation Events

44.1 The following Compensation Events unless they are caused by the Contractor:

- (a) The Employer does not give access to a part of the Site by the Site Possession Date stated in the Contract Data.
- (b) The Employer modifies the schedule of other contractors in a way which affects the work of the Contractor under the Contract.
- (c) The Engineer orders a delay or does not issue drawings, specifications or instructions required for execution of works on time.
- (d) The Engineer instructs the Contractor to uncover or to carry out additional tests upon work which is then found to have no Defects.
- (e) The Engineer does not approve of a subcontract to be let, within 15 days.
- (f) Ground conditions are substantially more adverse than could reasonably have been assumed before issuance of Letter of Acceptance from the information issued to Bidders (including the Site Investigation Reports), from information available publicly and from a visual inspection of the site.
- (g) The Engineer gives an instruction for dealing with an unforeseen condition caused by the Employer or additional work required for safety or other reasons.
- (h) Other contractors, public authorities, utilities or the Employer does not work within the dates and other constraints stated in the Contract, and they cause delay or extra cost to the Contractor.
- (i) The advance payment is delayed, beyond 28 days after receipt of application and bank guarantee.
- (j) The effect of the contractor of any of the Employer's Risks.
- (k) The Engineer unreasonably delays issuing a Certificate of Completion.
- (l) Other compensation Events listed in the Contract Data or mentioned in the Contract.

44.2 If a compensation event would cause additional cost or would prevent the work being completed before the Intended Completion Date, the Contract Price shall be increased and/or the Intended Completion Date is extended. The Engineer shall decide whether and by how much the Contract Price shall be increased and whether and by how much the Intended Completion Date shall be extended.

44.3 As soon as information demonstrating the effect of each Compensation Event upon the Contractor's forecast cost has been provided by the Contractor, it is to be assessed by the Engineer and the Contract Price shall be adjusted accordingly. If the Contractor's forecast is deemed unreasonable, the Engineer shall adjust the Contract Price based on Engineer's own forecast. The Engineer will assume that the Contractor will react competently and promptly to the event.

44.4 The Contractor shall not be entitled to compensation to the extent that the Employer's interests are adversely affected by the Contractor not having given early warning or not having cooperated with the Engineer.

45. Tax.

45.1 The rates quoted by the Contractor shall be deemed to be inclusive of the sales and other taxes that the Contractor will have to pay for the performance of this Contract. The Employer will perform such duties in regard to the deduction of such taxes at source as per applicable law.

46. Currencies.

46.1 All payments shall be made in Indian Rupees.

47. Price Adjustment.---{ Clause No.47 is not applicable }

- 47.1* ~~Contract price shall be adjusted for increase or decrease in rates and price of labour, materials, fuels and lubricants in accordance with the following principles and procedures and as per formula given in the contract data:~~
- (a) ~~The price adjustment shall apply for the work done from the start date given in the contract data up to end of the initial intended completion date or extensions granted by the Engineer and shall not apply to the work carried out beyond the stipulated time for the reasons attributable to the contractor.~~
- (b) ~~The price adjustment shall be determined during each month from the formula given in the contract data.~~
- (c) ~~Following expressions and meanings are assigned to the work done during each month:~~
- ~~R= Total value of work done during the month. It would include the amount of secured advance granted, if any, during the month, less the amount of secured advance recovered, if any during the month. It will exclude value for works executed under variations for which price adjustment will be worked separately based on the terms mutually agreed.~~
- ~~* Applicable for contracts of more than 12(twelve) months period.~~

- 47.2 To the extent that full compensation for any rise or fall in costs to the contractor is not covered by the provisions of this or other clauses in the contract, the unit rates and prices included in the contract shall be deemed to include amounts to cover the contingency of such other rise or fall in costs.

48. Retention.

- 48.1 The employer shall retain from each payment due to the Contractor the proportion stated in the Contract Data until Completion of the whole of the Works.
- 48.2 On completion of the whole of the works half the total amount retained is repaid to the Contractor and half when the Defects Liability Period has passed and the Engineer has certified that all Defects notified by the Engineer to the Contractor before the end of this period have been corrected.
- 48.3 In case, Contractor requests for refund of the Retention Money deducted by the Employer under the provision of this Clause, Employer shall consider the said request of the Contractor provided that the refund hereunder shall be made in tranches of not less than 1%(one percent) of the Contract Price and Contractor furnishes an irrevocable and unconditional bank guarantee for an equal amount substantially in the format of bank guarantee for performance guarantee enclosed with SBD and valid upto 28 days beyond the schedule/extended Defects Liability Period. On completion of the whole works, the Contractor has however an option to submit a fresh irrevocable and unconditional bank guarantee for an amount equal to 2.5% of the total value of work executed substantially in the format of bank guarantee for performance guarantee enclosed with SBD and valid upto 28 days beyond the Defects Liability Period and get refund the Retention Money and bank guarantees submitted for refund of Retention Money.

49. Liquidated Damages

- 49.1 The Contractor shall pay liquidated damages to the Employer at the rate per day stated in Contract Data for each day that the completion date is later than the Intended Completion Date (for the whole of the works or the milestone as stated in the contract data). The total amount of liquidated damages shall not exceed the amount defined in the Contract Data. The Employer may deduct liquidated damages from payments due to the Contractor. Payment of liquidated damages does not affect the Contractor's liabilities.
- 49.2 If the Intended Completion Date is extended after liquidated damages have been paid, the Engineer shall correct any overpayment of liquidated damages by the contractor by adjusting the next payment certificate. The Contractor shall be paid interest on the over payment calculated from the date of payment of repayment at the rate specified in Sub-Clause 43.1.

- 49.3 If the contractor fails to comply with the time for completion as stipulated in the tender, then the contractor shall pay to the employer the relevant sum stated in the Contract Data as Liquidated damages for such default and not as penalty for every date or part of day which shall elapse between relevant time for completion and the date stated in the taking over certificate of the whole of the works on the relevant section, subject to the limit stated in the Contract Data.

The Employer may, without prejudice to any other method of recovery deduct the amount of such damages from any monies due or to become due to the contractor. The payment of deduction of such damages shall not relieve the contractor from his obligation to complete the work on from any other of his obligations and liabilities under the contract.

- 49.4 If, before the Time for completion of the whole of the works or, if applicable, any Section, a Taking-Over Certificate has been issued for any part of the Works or of a Section, the liquidated damages for delay in completion of the remainder of the works or of that Section shall, for any period of delay after date stated in such Taking-Over Certificate, and in the absence of alternative provisions in the Contract, be reduced in the proportion which the value of the part so certified bears to the value of the whole of the Works or Section, as applicable. The provisions of this Sub-Clause shall only apply to the rate of liquidated damages and shall not affect the limit thereof.

50. Deleted.

51. Advance Payment(Not Applicable)

- 51.1 ~~The Employer shall make advance payment (not to be paid in less than two instalments except in special circumstances for which the reasons to be recorded in writing) to the contractor of the amounts stated in the contract data by the date stated in the contract data, against provision by the contractor of an unconditional bank guarantee in a form and by a bank acceptable to the Employer in amounts and currencies equal to be at least 110% of the advance payment. The guarantee shall remain effective until the advance payment has been repaid, but the amount of the guarantee shall be progressively reduced by the amounts repaid by the contractor. The mobilization advance would be deemed as interest bearing advance at an interest rate of 10% to be compounded quarterly.~~

- 51.2 ~~The Contractor is used to advance payment only to pay for Equipment, Plant and Mobilization expenses required specifically for execution of the work. The contractor shall demonstrate that advance payment has been used in this way by supplying copies of invoices or other documents to the Engineer.~~

- 51.3 ~~The advance payment shall be repaid by deducting proportionate amounts from payments otherwise due to the Contractor, following the schedule of completed percentage of the works on a payment basis. No account shall be taken of the advance payment or its repayment in assessing valuation of works done, variations, price adjustment, Compensations events or Liquidated Damages.~~

51.4. Secured Advance

~~The Engineer shall make advance payment in respect of materials intended for but not yet incorporated in the works in accordance with conditions stipulated in contract data.~~

52. Securities

- 52.1 The performance security (including additional security for unbalanced bids) shall be provided to the Employer no later than the date specified in the letter of acceptance and shall be issued in an amount and form and by a Bank or surety acceptable to the Employer and denominated in Indian Rupee. The Performance Security shall be valid until a date 28 days from the date of expiry of Defects Liability Period and the additional security for unbalanced bids shall be valid until a date 28 days from the date of issue of the certificate of completion.

53. Deleted

54. Cost of Repair

- 54.1 Loss or damaged to the works or materials to be incorporated in the works between the start date and the end of the defects correction period shall be remedied by the contractor at the contractor's cost if the loss or damages arises from the Contractor's acts or omissions.

E. FINISHING THE CONTRACT**55. Completion**

- 55.1 The Contractor shall request the Engineer to issue a certificate of completion of the works and the Engineer will do so upon deciding that the work is completed.

56. Taking Over

- 56.1 The Employer shall take over the site and the works within 7 days of the Engineer issuing a certificate of completion.

57. Final Account

- 57.1 The Contractor shall supply to the Engineer a detailed account of the total amount that the Contractor considers payable under the contract before the end of the defects liability period. The Engineer shall issue a defect liability certificate and certify any final payment that is due to the contractor within 56 days of receiving the contractor's account if it is correct and complete. If it is not, the Engineer shall issue within 56 days a schedule that states the scope of the correction or additions that are necessary. If the final account is still unsatisfactory after it has been resubmitted, the Engineer shall on the account payable to the Contractor and issue a payment certificate, within 56 days of receiving the contractor's revised account.

58. Operating and Maintenance Manuals

- 58.1 If "as built" drawings and/or operating and maintenance manuals are required, the contractor shall supply them by the dates stated in the contract data.
- 58.2 If the contractor does not supply the drawings and/or manuals by the dates stated in the contract data or they do not received Engineer's approval, the Engineer shall with hold the amount stated in the contract data from payments due to the contractor.

59. Termination

- 59.1 The Employer or the Contractor may terminate the Contract if the other party causes a fundamental breach of the contract.
- 59.2 Fundamental breaches of contract include, but shall not be limited to the following:
- (a) The Contractor stops work for 28 days when no stoppage of work is shown on the current programme and the stoppage has not been authorized by the Engineer;
 - (b) The Engineer instructs the Contractor to delay the progress of the works and the instruction is not withdrawn within 28 days.
 - (c) The employer or the contractor is made bankrupt or goes into liquidation other than for a reconstruction or amalgamation;
 - (d) A payment certified by the Engineer is not paid by the Employer to the Contractor within 56 days of the date of the Engineer's certificate;

- (e) The Engineer gives notice that failure to correct a particular Defect is a fundamental breach of Contract and the Contractor fails to correct it within a reasonable period of time determined by the Engineer;
- (f) The Contractor does not maintain a security which is required;
- (g) The Contractor has delayed the completion of works by the number of days for which the maximum amount of liquidated damages can be paid as defined in the Contract Data; and
- (h) If the Contract, in the judgment of the Employer has engaged in corrupt or fraudulent practices in competing for or in executing the Contract.

For the purpose of this paragraph: “corrupt practice” means the offering, giving, receiving or soliciting of anything of value to influence the action of a public official in the procurement process or in contract execution. “Fraudulent practice” means a misrepresentation of facts in order to influence a procurement process or the execution of a contract to the detriment of the Borrower, and includes collusive practice among Bidders (prior to or after bid submission) designed to establish bid prices at artificial non-competitive levels and to deprive the Borrower of the benefits of free and open competition”.

- 59.3 When either party to the Contract gives notice of a breach of contract to the Engineer for a cause other than those listed under Sub-Clause 59.2 above, the Engineer shall decide whether the breach is fundamental or not.
- 59.4 Notwithstanding the above, the Employer may terminate the Contract for convenience.
- 59.5 If the Contract is terminated the contractor shall stop work immediately, make the site safe and secure and leave the site as soon as reasonably possible.

60. Payment upon Termination.

- 60.1 If the contract is terminated because of a fundamental breach of Contract by the contractor, the Engineer shall issue a certificate for the value of the work done less advance payments received up to the date of issue of the certificate, less other recoveries due in terms of the contract, less taxes due to be deducted at source as per applicable law and less the percentage to apply to the work not completed as indicated in the Contract data. Additional Liquidation Damages shall not apply. If the total amount due to the Employer exceeds any payment due to the Contractor the difference shall be a debt payable to the Employer.
- 60.2 If the contract is terminated at the Employer’s convenience or because of a fundamental breach of Contract by the Employer, the Engineer shall issue a certificate for the value of the work done, the cost of balance material brought by the contractor and available at site, the reasonable cost of removal of equipment, repatriation of the contractor’s personnel employed solely on the works, and the Contractor’s costs of protecting and securing the works and less advance payments received up to the date of the certificate, less other recoveries due in terms of the contract and less taxes due to be deducted at source as per applicable law.

61. Property

- 61.1 All materials on the Site, Plant, Equipment, Temporary works and works are deemed to be the property of the Employer, if the Contract is terminated because of a Contractor’s default.

62. Releases from Performance

- 62.1 If the contract is frustrated by the outbreak of war or by any other event entirely outside the control of either the Employer or the Contractor the Engineer shall certify that the Contract has been frustrated. The Contractor shall make the site safe and stop work as quickly as possible after receiving this certificate and shall be paid for all work carried out before receiving it and for any work carried out afterwards to which commitment was made.

F. SPECIAL CONDITIONS OF CONTRACT.

1. LABOUR:

The contractor shall, unless otherwise provided in the Contract, make his own arrangements for the engagement of all staff and labour, local or other, and for their payment, housing, feeding and transport.

The contractor shall, if required by the Engineer, deliver to the Engineer a return in detail, in such form and such intervals as the Engineer may prescribe, showing the staff and the numbers of the several classes of labour from time to time employed by the Contractor on the Site and such other information as the Engineer may require.

2. COMPLIANCE WITH LABOUR REGULATIONS:

During continuance of the contract, the contractor and his sub-contractors shall abide at all times by all existing labour enactments and rules made there under, regulations, notifications and bye laws of the State or Central Government or local authority and any other labour law (including rules), regulations, bye laws that may be passed or notification that may be issued under any labour law in future either by the State or the Central Government or the local authority. Salient features of some of the major labour laws that are applicable to construction industry are given below. The Contractor shall keep the Employer indemnified in case any action is taken against the Employer by the competent authority on account of contravention of any of the provisions of any Act or rules made there under, regulations or notifications including amendments. If the Employer is caused to pay or reimburse, such amounts as may be necessary to cause or observe, or for non-observance of the provisions stipulated in the notifications/bye laws/Acts Rules/regulations including amendments, if any, on the part of the Contractor, the Engineer/Employer shall have the right to deduct any money due to the Contractor including his amount of performance security. The Employer/Engineer shall also have right to recover from the Contractor any sum required or estimated to be required for making good the loss or damage suffered by the Employer.

The employees of the Contractor and Sub-Contractor in no case shall be treated as the employees of the Employer at any point of time.

SALIENT FEATURES OF SOME MAJOR LABOUR LAWS APPLICABLE TO ESTABLISHMENTS ENGAGED IN BUILDING AND OTHER CONSTRUCTION WORK.

- (a) Workman Compensation Act 1923:- The Act provides for compensation in case of injury by accident arising out of and during the course of employment.
- (b) Payment of Gratuity Act 1972:- Gratuity is payable to an employee under the Act of satisfaction of certain conditions on separation if an employee has completed 5 years service or more on death, the rate of 15 days wages for every completed year of service. The Act is applicable to all establishments employing 10 more employees.
- (c) Employees P.F. and Miscellaneous Provision Act 1952:- The Act provides for monthly contributions by the employer plus workers @ 10% or 8.33%. The benefits payable under the Act are:
 - (i) Pension or family pension on retirement or death, as the case may be.
 - (ii) Deposit linked insurance on the death in harness of the worker.
 - (iii) Payment of P.F. accumulation on retirement/death etc.
- (d) Maternity Benefit Act 1951:- The Act provides for leave and some other benefits to women employees in case of confinement or miscarriage etc.

- (e) Contract Labour (Regulation & Abolition) Act 1970:- The Act provides for certain welfare measures to be provided by the Contractor to contract labour and in case the Contractor fails to provide, the same are required to be provided, by the Principal Employer by Law. The Principal Employer is required to take Certificate of Registration and the Contractor is required to take license from the designated Officer. The Act is applicable to the establishments or Contractor of Principal Employer, if they employ 20 or more contract labour.
- (f) Minimum Wages Act 1948:- The Employer is supposed to pay not less than the Minimum Wages fixed by appropriate Government as per provisions of the Act, if the employment is a scheduled employment. Construction of Buildings, Roads, Runways are scheduled employments.
- (g) Payment of Wages Act 1936:- It lays down as to by what date the wages are to be paid, when it will be paid and what deductions can be made from the wages of the workers.
- (h) Equal Remuneration Act 1979:- The Act provides for payment of equal wages for work of equal nature to Male and Female workers and for not making discrimination against female employees in the matters of transfers, training and promotion etc.
- (i) Payment of Bonus Act 1965:- The Act is applicable to all establishments employing 20 or more employees. The Act provides for payments of annual bonus subject to a minimum of 8.33% of wages and maximum of 20% of wages to employees drawing Rs. 3500/- per month or less. The bonus to be paid to employees getting Rs. 2500/- per month or above up to Rs.3500/- per month shall be worked out by taking wages at Rs. 2500/- per month only. The Act does not apply to certain establishments. The newly set-up establishments are exempted for five years in certain circumstances. Some of the State Governments have reduced the employment size from 20 to 10 for the purpose of applicability of this Act.
- (j) Industrial Disputes Act 1947:- The Act lays down the machinery and procedure for resolution of Industrial disputes, in what situation a strike or lock out becomes illegal and what are the requirements for laying off or retrenching the employees or closing down the establishment.
- (k) Industrial Employment (Standing Orders) Act 1946:- It is applicable to all establishments employing 100 or more workmen (employment size reduced by some of the State and Central Government to 50). The Act provides for laying down rules governing the conditions of employment by the Employer on matters provided in the Act and get the same certified by the designated Authority.
- (l) Trade Unions Act 1926:- The Act lays down the procedure for registration of trade unions of workmen and employers. The Trade Unions registered under the Act have been given certain immunities from Civil and criminal liabilities.
- (m) Child Labour (Prohibition & Regulation) Act 1986:- The Act prohibits employment of children below 14 years of age in certain occupations and processes and provides for regulation of employment of children in all other occupations and processes. Employment of Child Labour is prohibited in Building and Construction Industry.
- (n) Inter-State Migrant Workmen's (Regulation of Employment & Conditions of Service) Act 1979:- The Act is applicable to an establishment which employs 5 or more inter-state migrant workmen through an intermediary (who has recruited workmen in one state for employment in the establishment situated in another State). The Inter-State migrant workmen, in an establishment to which this Act becomes applicable, are required to be provided certain

facilities such as housing, medical aid, traveling expenses from home up to the establishment and back, etc.

- (o) The Building and Other Construction Workers (Regulation of Employment and Conditions of Service) Act 1996 and the Cess Act of 1996:- All the establishments who carry on any building or other construction work and employs 10 or more workers are covered under this Act. All such establishments are required to pay cess at the rate not exceeding 2% of the cost of construction as may be modified by the Government. The Employer of the establishment is required to provide safety measures at the Building or Construction work and other welfare measures, such as Canteens, First-Aid facilities, Ambulance, housing accommodation for workers near the work place etc. The Employer to whom the Act applies has to obtain a registration certificate from the Registering Officer appointed by the Government.
- (p) Factories Act 1948:- The Act lays down the procedure for approval of plans before setting up a factory, health and safety provisions, welfare provisions, working hours, annual earned leave and rendering information regarding accidents or dangerous occurrence to designated authorities. It is applicable to premises employing 10 persons or more with aid of power or 20 or more persons without the aid of power engaged in manufacturing process.

3. ARBITRATION (GCC Clause 25.3)

The procedure for arbitration will be as follows:

- 25.3 (a) In case of Dispute or difference arising between the Employer and a domestic contractor relating to any matter arising out of or connected with this Agreement, such dispute or difference shall be settled in accordance with the Arbitration and Conciliation Act, 1996. The parties shall make efforts to agree on a sole arbitrator and only if such an attempt does not succeed and the Arbitral Tribunal consisting of 3 arbitrators one each to be appointed by the employer and the Contractor and the third Arbitrator to be chosen by the two Arbitrators so appointed by the parties to act as Presiding Arbitrator shall be considered. In case of failure of the two arbitrators appointed by the parties to reach upon a consensus within a period of 30 days from the appointment of the arbitrator appointed subsequently, the Presiding Arbitrator shall be appointed by the * Council, Indian Roads Congress.
- (b) The Arbitral tribunal shall consist of three Arbitrators one each to be appointed by the Employer and the Contractor. The third Arbitrator shall be chosen by the two Arbitrators so appointed by the Parties, and shall act a presiding arbitrator. In case of failure of the two arbitrators by the parties to reach upon a consensus within a period of 30 days from the appointment of the arbitrator appointed consequently, the Presiding arbitrator shall be appointed by the * Council, Indian Roads Congress.
- (c) If one of the parties fails to appoint its arbitrator in pursuance of sub-clause (a) and (b) above within 30 days after receipt of the notice of the appointment of its arbitrator by the other party, then the * Council, Indian Roads Congress shall appoint the Arbitrator. A certified copy of the order of the Council, Indian Roads Congress, making such an appointment shall be furnished to each of the parties.
- (d) Arbitration proceedings shall be held in India, and the language of the arbitration proceedings and that of all documents and communications between the parties shall be English.
- (e) The decision of the majority of Arbitrators shall be final and binding upon both parties. The cost and expenses of Arbitration proceedings will be paid as determined by the arbitral tribunal. However, the expenses incurred by each party in connection with the preparation, presentation, etc. of its proceedings as also the fees and expenses paid to the arbitrator appointed by such party or on its behalf shall be borne by each party itself.
- (f) Performance under the contract shall continue during the arbitration proceedings and payments due to the contractor by the owners shall not be withheld, unless they are the subject matter of the arbitration proceedings.

G. ADDITIONAL CONDITIONS

1. In order to ensure submission of the work programme and approval of the same by the department before commencement of the work the following target dates are fixed for the related activities for compliance by all concerned:
 - A) The contractor after receiving the Letter of Acceptance shall furnish the work programme to the concerned Executive Engineer **within 14 (fourteen) days** from the date of issue of the Letter of Acceptance.
 - B) The Executive Engineer in turn shall forward the same after necessary scrutiny to the Superintending Engineer for onward transmission to the Chief Engineer **within 21(twenty one) days** from the date of issue of Letter of Acceptance. The work program should be based upon **M-S Project**.
 - C) The signing of the contract agreement will be subject to the acceptance of the work programme by the Chief Engineer.

2. From the date of taking over of site by contractor till the completion of the whole work, the entire responsibility for ****maintenance of the road portion** including the portions where the work is not yet started (in addition to the maintenance of the already executed works) shall lie with the contractor. In case the contractor fails to carry out the maintenance works, he will be notified by the Executive Engineer to execute the same. If the contractor still then fails to carry out the same within 7 days from the date of receiving instruction etc. from the Executive Engineer in writing, the Executive Engineer will be done the work and the cost thereof will be recovered from the contractor's next bill for the works. The maintenance of Road as required in the place of work is to be carried out as per the existing provisions of the road i.e. WBM/BUSG/PC/SC as may be applicable as per the direction of the Engineer in Charge.

3. Design & Drawing

- a) Embankment construction work shall be done as per IRC/MORTH specification and as per Direction of the Engineer-in-charge.
- b) Construction of CC Drain with cover will be done as per standard Design and drawing and as per direction of the Engineer-in-charge of work.
- c) Construction of RCC slab culvert and widening of RCC slab culvert as per IRC special publication-13, plate-4 and as per direction of the Engineer-in-charge.
- d) As regard unreinforced dowel jointed plain CC pavement and dry lean cement concrete, design and development of drawings shall be done by the contractor as per IRC:58:2002 (Second Revision), and other relevant IRC codes. Soil and other tests may be conducted by the contractor as prescribed in these codes, wherever felt necessary, before design and development of the drawings. The design note and drawings shall be submitted by the contractor to the department within one (1) month of award of the work. The design note and the drawings thus submitted shall be counter – checked or got proof – checked in an institute of repute by the department before formal issue and adoption for execution. Conduct of soil and other tests, design and development of the drawings shall be an integral part of the overall work and nothing extra shall be paid to the contractor on account of this. In the event that the design and the drawings are proof-checked by an institute of repute, the fee for proof -checking shall also be borne by the contractor from out of the overall contract amount and nothing extra shall be paid to him on this count.

4. The record of quality control test carried out in conformity with the technical specification No.900 and authenticated by the PWD staff shall be submitted to the Executive Engineer with every works bill and secured advance bill. The Executive Engineer will forward-process no bill without these test records. ~~to the MoRT&H's office.~~
5. The contractor after receiving the letter of acceptance shall furnish 3(three) Xerox copies of the contract agreement including the qualification criteria and other related papers forming the contract, as directed by the Department.
6. Deleted.
7. All testing must be carried from either of the following Laboratories/ Institutions:
 - a. I.I.T Guwahati
 - b. Road Research Laboratory , PWD Guwahati
 - c. NIT Yupia
 - d. NERIST

The sample from which the testing has to be conducted shall be decided by the Chief Engineer, Eastern Zone, PWD/ Engineer-in -Charge .

9. The following quality control equipments for field laboratory are to be kept at site for quality control tests.

A) For Earthwork :-

- i) Moisture Meter with chemicals
- ii) Apparatus for measuring Dry density by sand replacement method
- iii) Apparatus for measuring Dry density by core cutter method
- iv) Oven, electrically operated and thermostatically controlled upto 200⁰C & 300⁰C (sensitivity 1⁰C)
- v) Electronic balance of 200gm capacity 0.01 gm accuracy.
- vi) Madras Sand

B) For C.C. Pavement Work :-

- i) Set of IS sieves of all sizes both for coarse and fine aggregate (2 set of coarse and 2 set for fine aggregate)
- ii) Standard proctor Apparatus
- iii) Attenbarg limit liquid limit apparatus
- iv) Attenbarg limit plastic limit apparatus
- v) Auto Compaction
- vi) Rapid Moisture meter
- vii) Moisture container
- viii) Agg. Impact value machine with accessories
- ix) 3 m straight edge with wedge
- x) Water Bath (Thermostatically controller upto 600⁰C)
- xi) Softening Test Apparatus
- xii) Sand replacement Apparatus
- xiii) Core cutter with collar & hand hammer
- xiv) Electronic Balance (200 Gms-5 Kg)
- xv) Concrete Cube mould 7.06 cm x 7.06
- xvi) Concrete Mould (150x150x150 mm)
- xvii) Concrete Mould (50x50x50 mm)
- xviii) Motar Mould (70.6 x 70.6 x 70.6 mm)
- xix) Marshal stability Testing Machine
- xx) 500 KN electrically cum hand operated compressive Testing Machine.

10. Only TMT CRS reinforcing bars are to be used in the work. The same must bear certification from ISI marked reputed company or authorized dealer. The same must be approved by the Engineer-in Charge concerned
11. The Bid price to be rounded off at grand total amount arrived at after multiplication and summing up from detailed item wise rate and quantities to the nearest rupee by ignoring paise below fifty and to next rupee for amount with fifty paise or more. The ranking in the financial bid/comparative statement shall be based upon the rounded bid price.
12. It shall be ensured that for production of materials in crushers, boulders of minimum 150mm size are utilized for the purpose.
13. Collection of materials on the road sides should be so planned that it should commensurate with the physical progress of works and the collected materials should not cause any hindrance to the traffic. It must be ensured that contractor arranges for separate land for storage of road construction materials and machinery and these shall not be allowed to be stacked on roadside.
14. The work shall be executed as per CPWD specifications 1996 Vol-I to VI with upto date correction slips being followed in Arunachal Pradesh.
15. During the course of execution of work, traffic management shall be done in accordance with the guidelines contained in Ministry's letter No.RW/NH-11060/1/1998-DO.1, dtd. 07-10-87 and IRC:SP-55-2001" Guidelines on safety in construction zone".
16. The following road safety materials must used during the time of execution / diversion of traffic .
 - i) Traffic cone (385mm x 385mm base) x 722mm
 - ii) Safety jackets for labours/officers
 - iii) Safety helmets for labours/officers
 - iv) Safety reflective gloves
 - v) Pollution masks for labours & engineers
 - vi) Hand hold search light
 - vii) Led batons.
17. The display boards on development activities of the work shall be made as per guideline issued vide Ministry's letter No.RW/NH-33044/10/2000-S&R(R), dtd. 12-08-02.
18. Roughness measurements, as an aid to more effective monitoring of road construction and maintenance operation, will be taken before start and after completion of work as per guidelines circulated to the State PWD's in Ministry's letter No.RW/NH-33044/10/2000-S&R, dtd. 22-05-2000 and the same reported to the Ministry.
19. Video and Still Photography of the stretch to be improved/ renewed before and after execution of the work should be invariably done and records sent to the Ministry through this office for appreciation of work done.
20. Before actual execution, the borrow area for selected earth shall be exactly identified and got inspected and approved from an officer to be appointed by the Ministry.
21. ~~Copy of Ministry, New Delhi's circular No.RW/NH-24035/4/2008-P&M/PIC, dt.27.11.09 for reference. In case of any contradiction, the directive of Ministry's above circular dt.27.11.09 will prevail.~~
22. All taxes & levies ,cess etc shall be deducted as per Govt rules in addition to directives contain in Govt letter No. ADT.326/2009/43, dt.07.12.2009(Copy enclosed)
23. Each and every page constituting the bid submitted shall be signed /self attested by the authorized representative of the bidder before submitting online, failing which the bid will be summarily rejected.
24. Clause 1.1 of Conditions of Contract (i.e. definition of contract) under Section 3 and Sl.No.4 in the Contract Data under Section 4 have been amended as per Ministry, New Delhi's letter No.RW/NH-12014/5/2010/SP(MP)/P-9, dt.04.11.2010
25. Clause 51.1 of Conditions of Contract (Regarding mobilization advance) under Section 3 have been amended as per Ministry, New Delhi's letter No.RW/NH-24035/4/2008-P&M/PIC, dt.29.03.2011/01.04.2011

26. Inspection and Plants and Allied Machinery:

The plant and allied machinery required for execution work shall be inspected/examined by the technical committee constituted by the Employer.

27. The names of the Key personnel present at the site of work are to be recorded in the certificate of Bill of MB's while preparing and passing running/final bills. In the event of absence/non deployment of Key personnel during the contract period the amount stated at Annexure-III (below) are to be deducted per month on Pro-Rata Basis from the contractor's bill(s).

ANNEXURE-III

Designation of Key personnel	Amount to be deducted per month.
1 Project Manager	Rs. 60,000.00
2. Deputy Project Manager	Rs. 40,000.00
3. Project/Site Engineer	Rs. 25,000.00
4. Project Planning/ Quality/ Billing Engineer	Rs.15,000.00

28. Sale tax, Forest Royalty including other charges levied by the Forest Department on forest products including any other taxes as applicable is to be paid by the contractor. The department shall deduct the amount of GST, FR & ST and any taxes from the contractor's bill if the contractor fails to produce the valid certificates from the concerned departments.
29. The bid price to be rounded off at Grand Total amount arrived at after multiplication and summing up from detailed item wise rate and quantities to the nearest rupee by ignoring paise below fifty and to next rupee for amount with fifty paise or more. The ranking in the financial bid /comparative statement shall be based upon the rounded bid price.

* **Applicable for works costing Rs. 5.00Crore and above.**

** Clarification regarding maintenance of road during the period of construction

The maintenance of the road as required in the place of work is to be carried out as per the existing provision of the road as may be, complete as per the direction of the Engineer in-charge.

H. ADDITIONAL SPECIAL CONDITIONS

1. The Labour Cess @ 1% shall be deducted from Contractors Bill.
2. Collection of material on the road side, if any, should be commensurate with the physical progress of the work, so as to avoid any hindrance to traffic. It must be ensured that the contractor arranges for separate land for storage of road construction material and machinery and these shall not be allowed to be stacked on the road side. It shall be ensured that for production of materials in crushes, boulders of minimum 150 mm size are utilized for the purpose.
3. In conformity to this Ministry's Circular No. RW/NHIII/Coord/32/84 dtd 19/05/84, no work beyond the scope of the sanctioned estimate leading either to increase in the scope of the work or change in specifications should be undertaken without obtaining prior written approval of the Ministry.
4. Wherever applicable, the stipulations of IRC-37 2012 shall be followed in place of IRC-37 2007.

5. The work shall be executed as per Ministry's *Specification for Road & Bridge Works(Fifth revision-2003)* and instruction issued by the Ministry from time to time.
6. **Defect liability period : Any defect noticed on the work within a period of One year from the completion date of work shall be rectified by the contractor at his own cost failing which the same will be rectified by the department of his risk and cost.**
7. The firm work program as stipulated under Clause-27 of Section 3 *Condition of Contract* shall be prepared in MS Project and four sets of soft copy and hard copy shall be submitted to Executive Engineer in charge of the works.
8. From the date of taking over of site by contractor till the completion of the whole work, the entire responsibility for maintenance of the road portion including the portions where the work is not yet started(in addition to the maintenance of the already executed works) shall lie with the Contractor. In case the contractor fails to carry out the maintenance works, he will be notified by the Executive Engineer to execute the same. If the contractor still fails to carry out the same within 7 days from the date of receiving instruction etc. from the Executive Engineer in writing, the Executive Engineer will do the work and the cost thereof will be recovered from the contractor's next bill for the works.
9. The record of quality control test carried out in conformity with the technical specification No.900 and authenticated by the PWD staff shall be submitted to the Executive Engineer with every works bill and secured advance bill. The Executive Engineer will forward no bill to the office of the MORTH without these test records. The payment will be made by MORTH as per the D.P.P guidelines issued by the Ministry vide Memo No. PAO/NH/DPP/2000-01/2464-86 dtd 04/01/2000 including latest amendments.
10. The Bid price to be rounded off at grand total amount arrived at after multiplication and summing up from detailed item wise rate and quantities to the nearest rupee by ignoring paise below fifty and to next rupee for amount with fifty paise or more. The ranking in the financial bid/comparative statement shall be based upon the rounded bid price.
11. ~~The Contractor would provide an adequate site office along with required furniture, electricity, electrical fittings, drinking water facility, toilet, quality control equipment with consumable items, computer with related accessories and peripherals with office stationeries etc for the use of the departmental field officers/staff deputed for the inspection and supervision of the work or as directed by the Engineer in Charge from the date of commencement till the date of completion of the work. The cost of these facilities shall be inclusive in Bid value offered/accepted. No any extra claim shall be admissible for these facilities.~~
12. Collection of materials on the road sides should be so planned that it should commensurate with the physical progress of works and the collected materials should not cause any hindrance to the traffic. It must be ensured that contractor arranges for separate land for storage of road construction materials and machinery and these shall not be allowed to be stacked on roadside.

13. During the course of execution of work, traffic management shall be done in accordance with the guidelines contained in Ministry's letter No. RW/NH-11060/1/1998-DO.1 dtd. 07/10/87 and IRC: SP-55-2001 "Guidelines on safety in construction zone".
14. The display boards on development activities of the work shall be made as per guideline issued vide Ministry's letter No. RW/NH-33044/10/2000-S&R(R) dtd 12/08/02.
15. Roughness measurements, as an aid to more effective monitoring of road construction and maintenance operation, will be taken before start and after completion of work as per guidelines circulated to the state PWDs in Ministry's Letter No. RW/NH/33044/10/2000-S&R dtd. 22/05/2000 and the same reported to the Ministry.
16. Video and Still Photography of the stretch to be improved/renewed before and after execution of the work should be invariably done and records sent to the Ministry through Chief Engineer, Western one for appreciation of work done.
17. The test for stripping value shall be conducted at the rate of one test per 50 cum of bituminous mixed materials for bituminous work and also where the sources are changed. In case, the strip value is not satisfactory as per the specification, anti-stripping agent of required quality and quantity should be added to the satisfaction to the engineer-in-charge within the acceptable limit.
18. In case river shingles is used for crushing aggregates, the shingle sizes equal to or less than the twice of maximum size of aggregated in the bituminous layers and granular base course shall be excluded from the feed of the crusher through the appropriate screening.
19. **The qualification of the Project Engineers of the firm/bidder submitted shall be scrutinized through online. The appointment and authenticity of the project engineers appointed by the firm will be scrutinized.**

20. Arrangement of Inner Line Permit for the staff deployed in the project:-

All Indians, other than bonafide residents of Arunachal Pradesh, shall have to be arranged for inner line permit for entry in the state and their temporary stay in the state for the execution of works. Therefore, the successful bidders shall have to arrange inner line permit for their work force at their own cost. The inner line permit can be obtained prescribed application form, from the following officers:-

1. Resident Commissioner, Arunachal Bhawan Kautilya Marg, Chanakya Puri, New Delhi-21.
2. Deputy Resident Commissioner, Arunachal Bhawan Salt Lake, Kolkata.
3. Deputy Resident Commissioner, Arunachal Guest House, Mohanbari, Assam.
4. Deputy Resident Commissioner, Arunachal Bhawan, Guwahati, Assam.

The department can facilitate the arrangement of inner line permit by way of recommendation and authentication of the requirement to the inner line issuing authority.

~~Further, foreign nationals are required to obtain Restricted Area Permit (RAP) for entry into the state. The RAP shall be issued by the Department of Home, Govt. of Arunachal Pradesh,~~

~~Itanagar. The department of PWD can facilitate of arrangement of RAP by recommending and authenticating the requirement on submission of the record of valid passport and Visa for the employees required entering into the state for the purpose of the project.~~

27. Objections / complaints – Time Bar

Any objections/complaints pertaining to the technical bid shall be submitted within 3 (three) days of opening of the Technical Bid. Complaints submitted after said period shall not be entertained and the technical bids shall be processed without consideration of the objection/complaint. Once a technical bid has been approved, no further objections/ complaints on technical issues shall be entertained. In case of objections/complaints on financial bids, a similar procedure shall be adopted and the financial bids shall also be processed accordingly.

SPECIAL CONDITIONS FOR JOINT VENTURES APPLICANTS (Not Applicable)

1. ~~The bidder under an easting agreement in the form of joint venture (JV) shall have to submit a copy of the joint venture (JV) agreement entered in to by the partners with the technical bids. Alternatively, a letter of intent to execute a JV agreement in the event of successful bid, signed by all partners shall be submitted with the bid together with a copy of proposed agreement. The JV agreement shall include details of lead partners, supporting partners and the joint ventures objectives, the proposed management structure, the contributing of the each partner to the joint venture operation, the commitment of the partners to jointly and severely for due performance, resource/ sanctions within the JV in the event of default or withdrawal of any partner and arrangement for providing the required indemnities. JV partner would be limited to three (including the lead partners).~~

2. ~~One of the partners, who is the responsible for performing a key function in contract management or is executing a major component of the proposed contract, shall be nominated as being in charge during the bidding process and, in the event of successful bid, during contract execution. The partner in charge shall be authorized to incur liabilities and receive instructions for and on behalf of the partner(s) of the JV. This authorization shall be evidence by submitting a power of attorney signed by legally authorized signatories of all the partners and submitted with the bids.~~

3. ~~All the partners of the JV shall be, jointly and severally liable, during the bidding process and for the execution of the contract in accordance with the conduct terms, and statement to this effect shall be included in the authorization mentioned under clause 2. The bid shall be signed so as to legally bind all the partners, jointly and severally.~~

4. ~~Qualifying Criteria for Joint Ventures -~~
~~Joint Ventures must fulfill the following requirements:-~~
 - i) ~~The lead partner shall meet not less than 50% of all the qualifying criteria given in Para 4.5 A and 4.5 B (C) of ITB.~~
 - ii) ~~Each of the partners shall meet not less than 30% of all the qualifying criteria given in Para 4.5 A and 4.5 B (C) of ITB.~~
 - iii) ~~The JV must satisfactory collectively the criteria of Para(s) 4.5 A and 4.5 B (a), (b), (c) of ITB for which purpose the relevant figures for each of the partners shall be added together to arrive at the JV total capacity.~~
 - iv) ~~Every individual member of JV shall furnish the information in respect of firms as listed in clause 4.3(a), (b), (c), (d), (e), (f), (g), (i), (i) and a joint proposal for information listed in 4.3 (h), 4.30(k) and 4.3(1) of ITB. The information to be submitted by each individual firm shall be signed by authorized signatory of each firms. The joint proposal shall be submitted by the authorized~~

~~representative nominated by partners of JV [Note : The section 2 qualification information at Para 1.1, 1.2, 1.3.1, 1.3.2, 1.4(A), 1.4(b), 1.5, 1.6, 1.7, 1.8, 1.9, 1.10, 1.11, and 1.12 shall be submitted by each member of JV].~~

- ~~v) Each member of JV shall nominate the personnel to be deployed in the project from the information furnished vide Para 1.6 of qualification information.~~
- ~~vi) Each member of JV shall indent the T & P to be deployed in the project from the information furnished in the para 1.5 of the section 2 "Qualification information"~~

~~5. Joint venture agreement shall contain a clause to the effect that there shall be a separate JV bank account (distinct from the bank account of the individual partners) to which the individual partners shall contribute their share capital and/or working capital. JV agreement shall contain a clause to the effect that the financial obligation of the joint venture shall be discharged through the said JV bank account only and also all the payments received or paid by the ministry by the JV shall be through that account alone.~~

~~6. Each member of Joint Venture shall provide the information as detailed in the JV information sheet given below — Joint Venture Information Sheet~~

Joint venture Partner's legal name	
Joint venture Partners year of constitution	
Joint venture partners legal address in India	
Joint venture partners authorized representative information. Address— Telephone Number— And Email address—	

- ~~7. The formation of a joint venture after prequalification, any change in a prequalified joint venture will be subject to the written approval of the Employer prior to the deadline for submission of bids. Such approval shall be denied if (i) partners withdraw from a joint venture and the remaining partners do not meet the qualifying requirements; (ii) the new partners to a joint venture are not qualified individually or as another joint venture; or (iii) in the opinion of the Employer, a substantial reduction in competition may result.~~
- ~~8. Bid shall be signed so as to legally bind all partners, jointly and severally, and shall be submitted with a copy of the joint venture agreement providing the joint and several liability with respect to the contract.~~

BLANK

SECTION 4

CONTRACT DATA

BLANK

CONTRACT DATA

**Clause Reference
with respect to section 3**

Items marked “N/A” do not apply in this Contract.

1. The Employer is [Cl.1.1]
 Name: **Chief Engineer, Eastern Zone, PWD, AP**
 Address: **Namsai**
Arunachal Pradesh : 792103

2. The Engineer is ; **Executive Engineer, Tezu Division, PWD, AP, Tezu.**
 Name of authorized Representatives: **Assistant Engineer, Tezu Sub-Division, PWD, AP, Tezu.**

3. The Dispute Review Expert appointed jointly by the Employer and Contractor is: [Cl.1.1]
Will be decided later through IRC, New Delhi mutual discussion with successful bidder.

4. The Defects Liability Period is **One year** from the date of completion as per Circular No. NH-11065/4/2012-P&M (Pt-II) dated 12.04.2012. [Cl.1.1& 35]

5. The start Date shall be 21 (Twenty One) days from the date of issue of the Notice to proceed with the work. [Cl.1.1]

6. The Intended Completion Date for the whole of the Works is 24 **(Twenty four)** months after start of work with the following milestones. [Cl.1.1,17& 28]
 Milestone dates: [Cl. 2.2 & 49.1]

Physical works to be completed	Period from the start date
Milestone 1 i.e. 25 %	06 (Six) months
Milestone 2 i.e. 65 %	15 (Fifteen) months
Milestone 3 i.e. 100 %	24 (Twenty four) months

7. The Site is located within Tezu Township under Lohit District, Arunachal Pradesh. [Cl.1.1]

8. Estimate for “**Construction of C.C. road in Tezu Township**”. [Cl.1.1]

9. The works consists of Embankment construction, DLC, PQC, C.C. Drain and C.D. Structure which should inter-alia include the following as applicable: [Cl.1.1]

(A) Road Works

Site clearance; setting-out and layout; widening of existing carriageway and strengthening including camber corrections; construction of new road/parallel service road; bituminous pavements remodeling/construction of junctions, intersections, bus bays, lay bays; supplying and placing of drainage channels, flumes, guard posts and guard other related items; construction/extension of cross drainage works, bridges, approaches and other related stones; road markings, road signs and kilometer/ hectometer stones; protective works for roads/bridges; all aspects of quality assurance of various components of the works; rectification of the defects in the completed works during the Defects Liability Period; submission of "As- built" drawings and any other related documents; and other item of work as may be required to be carried out for completing the works in accordance with the drawings and provisions of the contract to ensure safety.

(B) Bridge Works/ Slab Culverts

Site clearance; setting out, provision of steel superstructure foundations, piers, abutments, tower for suspension bridge and bearings; prestressed/reinforced cement concrete superstructure; Stiffening girder for suspension bridge, wearing coat, hand railings, expansion joints, approach slabs, drainage spouts/downtake pipes, arrangements for fixing light posts, water mains, utilities etc; provision of suitably designed protective works; providing wing/return walls; provision of road markings, road signs etc.; all aspects of quality assurance; clearing the site and handing over the works on completion; rectification of the defects during the Defects Liability Period and submission of "As-built" drawings and other related documents; and other items of work as may be required to be carried out for completing the works in accordance with the drawings and the provisions of the contract and to Insure safety.

(C) Other Items

	Any other items as required to fulfill all contractual obligations as per the Bid documents.	[C1.1.1]
10	The following documents also form part of the Contract Document listed in <u>Sl.No.1 to 9 of Clause-2.3, Amendments and Special conditions.</u>	[C1.2.3(9)]
11	The law which applies to the Contract is the law of Union of India	[C1.3.1]
12	The language of the Contract documents is English	[C1.3.1]
13	Limit of subcontracting Nil % of the Initial Contract Price	[C1.7.1]
14	The Schedule of Other Contractors: Departmental workers and local contractors approved by Engineer.	[C1.8]
15	The Schedule of Key Personnel As per Annex.-II to Section-I	[C1.9]
16	The minimum insurance cover for physical property, injury and death is Rs. 5 lakhs per occurrence with the number of occurrences limited to four. After each occurrence, contractor will pay additional premium necessary to make insurance valid for four occurrences always.	[C1.13]
17	Site investigation report ;	[C1.14]
18	The Site Possession Dates shall be from 10(Ten) days after the date of notice to proceed with the work	[C1.21]

- 19 Fees and types of reimbursable expenses to be paid to the Dispute Review Expert
(To be inserted later) [Cl.25]
- 20 Appointing Authority for the Dispute Review Expert -~~Council, Indian Roads Congress, New Delhi.~~ **Will be decided later through mutual discussion with successful bidder.** [Cl.26]
- 21 The period for submission of the programme for approval of the Employer/Engineer in charge shall be **14 days** from the issue of Letter of Acceptance. [Cl.27.1]
- 22 The period between programme updates shall be **30(Thirty)** days. [Cl.27.3]
- 23 The amount to be with held for late submission of an updated programme shall be **Rs. 5.00 lakhs.** [Cl.27.3]
- 24 ~~The following events shall also be Compensation Events:~~ [Cl.44]
~~Substantially adverse ground conditions encountered during the course of execution of work not provided for in the bidding document~~
- ~~(i) Removal of underground utilities detected subsequently~~
 - ~~(ii) Significant change in classification of soil requiring additional mobilization by the contractor, e.g. ordinary soil to rock excavation,~~
 - ~~(iii) Removal of unsuitable material like marsh, debris dumps, etc not caused by the contractor~~
 - ~~(iv) Artesian conditions~~
 - ~~(v) Seepage, erosion, landslide~~
 - ~~(vi) River training requiring protection of permanent work~~
 - ~~(vii) Presence of historical, archeological or religious structures, monuments interfering with the works~~
 - ~~(viii) Restriction of access to ground imposed by civil, judicial, or military authority~~
- 25 The currency of the Contract is **Indian Rupees.** [Cl.46]
26. The formula (e) for adjustment of prices are : — [Cl.47]
 ~~$R = \text{Value of work as defined in Clause 47.1 of Conditions of Contract}$~~
- Adjustment for labour component .(Not Applicable)**
- (i) ~~Price adjustment for increase or decrease in the cost due to labour shall be paid in accordance with the following formula:~~
- ~~$$V_L = 0.85 \times P_1 / 100 \times R \times (L_1 - L_0) / L_0$$

$$V_L = \text{increase or decrease in the cost of work during the month under consideration due to changes in rates for local labour.}$$~~

L_0 = the consumer price index for industrial workers for the State on 28 days preceding the date of opening of Bids as published by labour Bureau, Ministry of Labour, Government of India.

L_1 = the consumer price index for industrial workers for the State for the under consideration as published by Labour Bureau, Ministry of Labour, Government of India.

P_1 = Percentage of labour component of the work.

Adjustment for cement (Gray cement) component. (Not Applicable)

(ii) Price adjustment for increase or decrease in the cost of cement (Gray cement) procured by the Contractor shall be in accordance with the following formula:

$$V_c = 0.85 \times P_c / 100 \times R \times (C_1 - C_0) / C_0$$

V_c = increase or decrease in the cost of work during the month under consideration due to changes in rates of cement (Gray cement).

C_0 = the all India wholesale price index for cement (Gray cement) on 28 days preceding the date of opening of Bids as published by the Ministry of Industrial Development, Government of India, New Delhi

C_1 = the all India average wholesale price index for cement (Gray cement) for the month under consideration as published by Ministry of Industrial Development, Government of India, New Delhi

P_c = Percentage of cement (Gray cement) component of the work.

Adjustment for steel component. (Not Applicable)

(iii) Price adjustment for increase or decrease in the cost due to steel procured by the Contractor shall be paid in accordance with the following formula:

$$V_s = 0.85 \times P_s / 100 \times R \times (S_1 - S_0) / S_0$$

V_s = increase or decrease in the cost of work during the month under consideration due to changes in rates for steel.

S_0 = the all India wholesale price index for steel (Rebars) on 28 days preceding the date of opening of Bids as published by the Ministry of Industrial Development, Government of India, New Delhi

S_1 = the all India average wholesale price index for steel (Rebars) for the month under consideration as published by Ministry of Industrial Development, Government of India, New Delhi

P_s = Percentage of steel component of the work.

Note: For the application of this clause, index of Rebars has been chosen to represent steel group.

Adjustment for bitumen component. (Not Applicable)

(iv) Price adjustment for increase or decrease in the cost of bitumen shall be paid in accordance with the following formula:

$$V_b = 0.85 \times P_b / 100 \times R \times (B_1 - B_0) / B_0$$

V_b = increase or decrease in the cost of work during the month under consideration due to changes in rates for bitumen

B_0 = the official retail price of bitumen at the IOC depot at nearest center on the day 28 days prior to date of opening of Bids.

B_1 = the official retail price of bitumen of IOC depot at nearest center for the 15th day of the month under consideration.

P_b = Percentage of bitumen component of the work.

Clause Reference
With respect
To section 3

Adjustment of POL (fuel and lubricant) component. (Not Applicable)

(v) Price adjustment for increase or decrease in the cost of POL (fuel and lubricant) shall be paid in accordance with the following formula:

$$V_f = 0.85 \times P_f / 100 \times R \times (F_+ - F_0) / F_0$$

V_f = increase or decrease in the cost of work during the month under consideration due to changes in rates for fuel and lubricants.

F_0 = the official retail price of High Speed Diesel (HSD) at the existing consumer pumps of IOC at the nearest on the day 28 days prior to the date of opening of Bids.

F_+ = the official retail price of High Speed Diesel (HSD) at the existing consumer pumps of IOC at the nearest center for the 15th day of month of the under consideration.

P_f = Percentage of fuel and lubricants component of the work.

Note : For the application of this clause, the price of High Speed Diesel oil has chosen to represent fuel and lubricants group.

Adjustment for Plant and Machinery Spares component. (Not Applicable)

(vi) Price adjustment for increase or decrease in the cost of Plant and Machinery spares Component shall be paid in accordance with the following formula:

$$V_p = 0.85 \times P_p / 100 \times R \times (P_+ - P_0) / P_0$$

V_p = increase or decrease in the cost of work during the month under consideration due to changes in rates for Plant and Machinery spares

P_0 = the all India wholesale price index for Construction Machinery on 28 days preceding the date of opening of Bids as published by the Ministry of Industrial Development, Government of India, New Delhi

P_+ = the all India average wholesale price index for Construction Machinery for the month under consideration as published by the Ministry of Industrial Development, Government of India, New Delhi

P_p = Percentage of Plant and Machinery spares component of the work.

Note : For the application of this clause, index of Construction Machinery has been chosen to represent the plant and machinery spares group.

Adjustment of Other material Component. (Not Applicable)

(vii) Price adjustment for increase or decrease in the cost of local materials other than cement, steel, bitumen and POL procured by the contractor shall be paid in accordance with the following formula:

$$V_m = 0.85 \times P_m / 100 \times R \times (M_+ - M_0) / M_0$$

V_m = increase or decrease in the cost of work during the month under consideration due to changes in rates for local materials other than cement, steel, bitumen and POL

M_0 = the all India wholesale price index (all commodities) on 28 days preceding the date of opening of Bids as published by the Ministry of Industrial Development, Government of India, New Delhi

M_+ = the all India average wholesale price index (all commodities) for the month under consideration as published by the Ministry of Industrial Development, Government of India, New Delhi

P_m = Percentage of local material (other than cement, steel, bitumen and POL) of the work.

The following percentages will govern the price adjustment for the entire contract in general: { **Not applicable** }

1.	Labour P1.....	_____
2.	Cement Pc.....	_____
3.	Steel.....	_____
4.	Bitumen Pb.....	_____
5.	POL Pf.....	_____
6.	Plant & Machinery Spares Pp.....	_____
7.	Other materials Pm.....	_____
	Total	_____

{ **Not applicable** }

27. The proportion of payments retained (retention money) shall be **2.50%** from each bill subject to a maximum of 5% of final contract price. [Cl.48]
28. Amount of liquidated damages for Delay in completion of works [Cl.49]
- Mile stone 1 --- Rs.10000.00per day
Mile stone 2 --- Rs.38000.00per day
29. Maximum limit of liquidated damages for delay in completion of work 10 percent of the Initial Contract price rounded off to the nearest thousand. [Cl.49]
30. ~~Amount of Bonus for early completion of whole of the works~~ : Deleted [Cl.50]
31. ~~Maximum limit of bonus for early completion of work~~ : Deleted [Cl.50]
32. The amounts of the advanced payment are : (NOT APPLICABLE)
- Nature of advance Amount (Rs.) Condition to be fulfilled** [Cl.51 & 52]
- i) *Mobilization 10% of the contract price On submission of unconditional Bank Guarantee (to be drawn before the end of 20% of Contract period). The Contractor may furnish four bank guarantees of 2.5% each, valid for full period.
- ii) *Equipment 90% for new and 50% of depreciated value for old equipment. Total amount will be subject to a maximum of 5% of The Contract Price. After equipment is brought to site (provided the Engineer is satisfied that the equipment is required for performance of the contract) and on submission of unconditional Bank Guarantee for amount of advance.

*Not applicable for works of sanctioned amount below Rs.2.00 Cr.

- iii) Secured ~~75% of Invoice value~~ a) ~~the materials are in-~~
~~advance for~~ ~~accordance with the~~
~~non-perish-~~ ~~specification for work;~~
~~able materials~~
~~brought to site~~ b) Such materials have been
delivered to site, and are
properly stored and protected
against damage or deterior-
ation to the satisfaction of the
Engineer. The Contractor shall
Store the bulk material in
Measurable stacks.
- e) ~~the Contractor's records of~~
~~the requirements, orders, receipt~~
~~and use of materials are kept in~~
~~a form approved by the Engineer~~
~~and such records shall be available~~
~~for inspection by the Engineer.~~
- d) ~~The Contractor has submitted with~~
~~His monthly statement the estimated~~
~~value of the materials on site together~~
~~with such documents as may be~~
~~required by the Engineer for the~~
~~purpose of valuation of the materials~~
~~and providing evidence of ownership~~
~~and payment thereof.~~
- e) ~~Ownership of such materials shall be~~
~~Deemed to vest in the Employer~~
~~For which the Contractor has~~
~~Submitted an Indemnity Bond in an~~
~~Acceptable format; and~~
- f) ~~The quantities of materials are not~~
~~Excessive and shall be used within~~
~~a reasonable time as determined by~~
~~the Engineer.~~

(The advance payment will be paid to the Contractor no later than 28 days after fulfillment of the above conditions).

33. Repayment of advance payment for mobilization and equipments: ~~_____~~ [Cl.51.3]
The advance loan shall be repaid with percentage deductions from the
Interim payments certified by the Engineer under the Contract. Deductions
Shall commence in the next Interim Payment Certificate following that
In which that total of all such payments to the Contractor has reached
not less than 20 percent of the Contract Price or 6(Six) months from the
date of payment of first installment of advance, whichever period concludes
earlier, and shall be made at the rate of 20 percent of the amounts of all
Interim payment certificates until such time as the loan has been repaid,
always provided that the loan shall be completed repaid prior to the
expiry of the original time for completion pursuant to Clause 17 and 28.

Clause Reference
With respect
To section 3

34. ~~Repayment of secured advance:~~ [Cl.51.4]
~~The advance shall be repaid from each succeeding monthly payments to~~
~~The extent materials [for which advance was previously paid pursuant to~~
~~Clause 51.4 of G.C.C.] have been incorporated in to the works.~~
35. The Securities shall be for the following minimum amounts equivalent as [Cl.52]
a percentage of the Contract Price:
Performance security for 5 percent of contract price plus Rs.
(to be decided after evaluation of the bid) as additional security items of
ITB Clause 29.5.
- The standard form of performance Security acceptable to the Employer
shall be an unconditional bank Guarantee of the type as presented in
Section 8 of the Bidding Documents.
36. The Schedule of operating and maintenance manuals N/A [Cl.58]
37. The date by which “As-built drawings (in scale as directed) in 2 sets are
required is within 28 days of issue of certificate of completion of whole
or section of the work, as the case may be.N/A [Cl.58]
38. The amount to be withheld for failing to supply “As-built” drawings by
the date required is Rs. lakhs..... N/A [Cl.58]
39. The following events shall also be fundamental breach of contract: [Cl.59.2]

“The Contract has contravened Sub-clause 7.1 and Clause 9 of G.C.C.”
40. The percentage to apply to the value of the work not completed [3,Cl.60]
representing the Employer’s additional cost for completing the Works
shall be 20 percent.

SECTION-5
TECHNICAL SPECIFICATIONS

BLANK

Technical Specification

Introduction

1. The work shall be in general carried out as per CPWD Specification 2019 Vol-I &II with upto date correction slips as being following in Arunachal Pradesh. The items not covered in the above specification shall be carried out as per the relevant latest BIS specification, the same shall be executed as per the specification available in other foreign countries or as per the literature published in referred International Journals and as per directions of the Engineer-in-charge.
2. The bidders are expected to be well versed with the relevant specifications of the item of works involved in the tender, the following books of specification:
 - I. Specification for Road and Bridge Works; published by IRC for MORTH
 - II. CPWD specifications
 - III. BIS specifications
 - IV. IRC Specifications
 - V. Standard specifications and code of practice for construction of concrete roads forth revision IRC-15-2011.
 - VI. Guidelines for the design of plain jointed rigid pavements for Highways second revision IRC: 58: 2002.

The following abbreviations shall have the meaning as given below:-

AASHTO	American Association of State Highway and Transportation Officials.
ASTM	American Society for Testing and Materials.
BS	British Standard Published by the British Standards Institution.
CBR	California Bearing Ratios.
IRC	Indian Road Congress.
IS	Indian Standard Published by the Bureau of Indian Standards.
MOS,RT&H	Ministry of Shipping, Road Transport and Highways.

BLANK

SECTION – 6
FORM OF BID

(Furnished separately in Vol.-II)

BLANK

SECTION – 7
BILL OF QUANTITIES

(Furnished separately in Vol.- II)

BLANK

SECTION-8
SECURITIES AND OTHERS FORM

(To be filled by Bidder/ Employer)

BLANK

BID SECURITY (BANK GUARANTEE)

WHEREAS, _____ [name of Bidder] (hereinafter called "the Bidder") has submitted his bid dated _____ [date] for construction of _____ [name of Contract hereinafter called "the Bid"].

KNOW ALL PEOPLE by these presents that We _____ [name of Bank] of _____ [name of country] having our registered office at _____ [hereinafter called "the Bank") are bound unto _____ [name of Employer] (herein after Called "the Employer") in the sum of _____ * for which payment Well and truly to be made to the said Employer or officer authorized by the Employer the Bank itself, his successors and assigns by these presents.

SEALED with the Common Seal of the said Bank this _____ day of _____ 20 _____.

THE CONDITIONS of this obligation are:

- (1) If after Bid opening the Bidder withdraws his Bid during the period of Bid validity specified in the Form of Bid.

OR

- (2) If the Bidder having been notified to the acceptance of his bid by the Employer during the period of Bid validity.
 - (a) Fails or refuses to execute the Form of Agreement in accordance with the Instructions to Bidders, if required; or
 - (b) Fails or refuses to furnish the Performance Security, in accordance with the Instructions to Bidders; or
 - (c) Does not accept the correction of the Bid price pursuant to Clause 27.

We undertake to pay to the Employer up to the above amount upon receipt of his first written demand, without the Employer having to substantiate his demand, provided that in his demand the Employer will note that the amount claimed by him is due to him owing to the occurrence of one or any of the three conditions, specifying the occurred condition or conditions.

This Guarantee will remain in force up to and including the date _____ ** days after the deadline for submission of Bids as such deadline is started in the Instructions to Bidder or as it may be extended by the Employer, notice of which extension (s) to the bank is hereby waived. Any demand in respect of this guarantee should reach the Bank not later than above date.

DATE _____ SIGNATURE _____

WITNESS _____ SEAL _____

[Signature, name and address]

*The Bidder should insert the amount of the guarantee in words and figures denominated in Indian Rupees. This figure should be the same as shown in Clause 16.1 of the Instructions to Bidders.

**45 days after the end of the validity period of the Bid.

PERFORMANCE BANK GUARANTEE

To

The Executive Engineer, Tezu Division,[Authorized representative of the Employer]
..... [Address of Authorized representative of the Employer]

WHEREAS _____ [name and address of Contractor] (hereinafter called “the Contractor”) has undertaken, in pursuance of Contract No. _____ dated _____ to execute _____ [name of Contract and brief description of works] (hereinafter called “the Contractor”).

AND WHEREAS it has been stipulated by you in the said Contract that the Contractor shall furnish you with a Bank Guarantee by a recognized bank for the sum specified therein as security for compliance with his obligation in accordance with the Contract;

AND WHEREAS we have agreed to give the Contractor such a Bank Guarantee:

NOW THEREFORE we hereby affirm that we are the Guarantor and responsible to you on behalf of the Contractor, up to a total of _____ [amount of guarantee]* _____ (in words), such sum being payable in the types and proportions of currencies in which the Contract price is payable, and we undertake to pay you, upon your first written demand and without cavil or argument, any sum or sums within the limits of _____ amount of guarantee] as aforesaid without your needing to prove or to show grounds pr reasons for your demand for the sum specified therein.

We hereby waive the necessary of your demanding the said debt from the contractor before presenting us with the demand.

We further agree that no change or addition to or other modification of the terms of the Contract or of the works to be performed there under or of any of the Contract documents which may be made between your and the Contractor shall in any way release us from any liability under this guarantee, and we hereby waive notice of any such change, addition or modification.

This guarantee shall be valid until 28 days from the date of expiry of the Defect Liability Period.

Signature and Seal of the guarantor _____
Name of Bank _____
Address _____
Date _____

*An amount shall be inserted by the Guarantor, representing the percentage of Contract Price specified in the Contract including additional security for unbalanced Bids, if any and denominated in Indian Rupees.

BANK GUARANTEE FOR ADVANCE PAYMENT

To
The Executive Engineer, Tezu Division,[Authorized representative of the Employer]
..... [Address of Authorized representative of the Employer]
_____ [Name of Contractor]

Gentlemen:

In accordance with the provisions of the Conditions of Contract, sub-clause 51.1(“Advance Payment”) of the above mentioned Contract, _____ [name and address of the Contractor] (hereinafter called “the Contractor”) shall deposit with _____ [name of Employer] a bank guarantee to guarantee his proper and faithful performance under the said Clause of the Contract in an amount of _____ [amount of guarantee]* _____ [in words].

We, the _____ [bank of financial institution], as instructed by the Contractor, agree unconditionally and irrevocably to guarantee as primary obligator and not surety merely, the payment to _____ [name of Employer] on his first demand without whatsoever right of obligation on our part and without his first claim to the Contractor, in the amount not exceeding _____ [amount of guarantee]* _____ [in words].

We further agree that no change or addition to or other modification of the terms of the Contractor of works to be performed there under or of any of the Contract documents which may be made between _____ [name of Employer] and the Contractor, shall in any way release us from any liability under this guarantee, and we hereby waive notice of any such change, addition or modification.

This guarantee shall remain valid and full effect from the date of the advance payment under the Contract until _____ [name of Employer] receives full repayment of the same amount from the Contractor.

Yours truly,

Signature and Seal _____
Name of Bank /Financial Institution _____
Address _____
Date _____

*An amount shall be inserted by the Bank or Financial Institution, representing the amount of the Advance Payment, and denominated in Indian Rupees.

INDENTURE FOR SECURED ADVANCES
FORM 31

(For use in cases in which the contract is for finished work and the contractor has entered into an agreement for the execution of a certain specified quantity of work in a given time)

This indenture made the _____ day of _____ 20____ BETWEEN _____ (hereinafter called the Contractor which expression shall where the context so admits or implies be deemed to include his executors, administrator and assigns) or the one part and the Employer of the other part.

Whereas by an agreement dated _____ (hereinafter called the said agreement) the contractor has agreed.

AND WHEREAS the contractor has applied to the Employer that he may be allowed advanced on the security of materials absolutely belonging to him and brought by him to the site of the works the subject of the said agreement for use in the construction of such of the works as he has undertaken to executive at rates fixed for the finished work (inclusive of the cost of materials and labour and other charges).

AND WHEREAS the Employer has agreed to advance to the Contractor the sum of Rupees _____ on the security of materials the quantities and other particulars of which are detailed in Accounts of Secured advances attached to the Running Account Bill for the said works signed by the Contractor on _____ and the Employer has reserved to himself the option of making any further advance or advances on the security of other materials brought by the Contractor to the site of the said works.

Now THIS INDENTURE WITNESSETH that in pursuance of the said agreement and in consideration of the sum of Rupees _____ on or before the execution of these presents paid to the Contractor by the Employer (the receipt where of the Contractor doth hereby acknowledge) and of such further advances (if any) as may be made to him as a for said Contractor doth hereby covenant and agree with the President and declare as follows:

- (1) That the said sum of Rupees _____ so advanced by the Employer to the Contractor as aforesaid and all or any further sum of sums advanced as aforesaid shall be employed by the Contractor in or towards expending the execution of the said works and for no other purpose whatsoever.
- (2) That the materials details in the said Account of Secured Advances which have been offered to and accepted by the Employer as security are absolutely the Contractor's own property and free from encumbrances of any kind and the contractor will not make any application for or receive a further advance on the security of materials which are not absolutely his own property and free from encumbrances of any kind and the Contractor indemnified the Employer against all claims to any materials in respect of which an advance has be made to him as aforesaid.
- (3) That the materials detailed in the said account of Secured Advances and all other materials on the security of which any further advance or advances may hereafter be made as aforesaid (hereafter called the said materials) shall be used by the Contractor solely in the execution of the said works in accordance with the directions of the Engineer.
- (4) That the contractor shall make at his own cost all necessary and adequate arrangements for the proper watch, safe custody and protection against all risks of the said materials and that until used in construction as aforesaid the said materials shall remain at the site of the said works in the Contractor's custody and on his own responsibility and shall at all times be open to inspection by the Engineer or any officer authorized by him. In the event of the said materials or any part thereof being stolen, destroyed or damaged or becoming deteriorated in a greater degree than is due to reasonable use and wear thereof the Contractor will forthwith replace the same with other materials of like quality or repair and make good the same required by the Engineer.

- (5) That the said materials shall not be any account be removed from the site of the said works except with the written permission of the Engineer or an officer authorized by him on that behalf.
- (6) That the advances shall be repayable in full when or before the Contractor receives payment from the Employer of the price payable to him for the said works under the terms and provisions of the said agreement. Provided that if any intermediate payments are made to the Contractor on account of work done than on the occasion of each such payment the Employer will be at liberty to make a recovery from the Contractor's Bill for such payment by deducting there from the value of the said materials than actually used in the construction and in respect of which recovery has not been made previously, the value for this purpose being determined in respect of each description of materials at the rates at which the amounts of the advances made under these presents were calculated.
- (7) That if the Contractor shall at any time make any default in the performance or observance in any respect of any of the terms and provisions of the said agreement or of these presents the total amount of the advance or advances that may still be owing of the Employer shall immediately on the happening of such default be repayable by the Contractor to be the Employer together with interest thereon at twelve percent per annum from the date or respective dates of such advance or advances to the date of repayment and with all costs, charge, damages and expenses incurred by the Employer in or for the recovery thereof or the enforcement of this security or otherwise by reason of the default of the Contractor and the Contractor hereby covenants and agrees with the Employer to reply and pay the same respectively to him accordingly.
- (8) That the contractor hereby charges all the said materials with the repayment to the Employer of the said sum of Rupees _____ and any further sum of sums advanced as aforesaid and all costs, charges, damages and expenses payable under these presents PROVIDED ALWAYS and it is hereby agreed and declared that notwithstanding anything in the said agreement and without prejudice to the power contained therein and whenever the covenant for payment and repayment herein before contained shall become enforceable and the money owing shall not be paid in accordance there with the Employer may at any time thereafter adopt all or any of the following courses as he may deem best:
- (a) Seize and utilize the said materials or any part thereof in the completion of the said works on behalf of the contractor in accordance with the provisions in that behalf contained in the said agreement debiting the contractor with the actual cost of effecting such completion and the amount due to the contractor with the value of work done as if he has carried it out in accordance with the said agreement and at the rates thereby provided. If the balance is against the contractor, he is to pay same to the **Employer** on demand.
 - (b) Remove and sell by public auction the seized materials or any part thereof and out of the moneys arising from the sale retain all the sums aforesaid repayable or payable to the **Employer** under these presents and pay over the surplus (if any) to the Contractor.
 - (c) Deduct all or any part of the moneys owing out of the security deposit or any sum due to the Contractor under the said agreement.
- (9) That except in the event of such default on the part of the contractor as aforesaid interest on the said advance shall not be payable.
- (10) That in the event of any conflict between the provisions of these presents and the said agreement the provisions of these presents shall prevail and in the event of any dispute or difference arising over the construction or effect of these presents the settlement of which has not been here-in-before expressly provided for the same shall be referred to the Employer whose decision shall be final and the provision of the Indian Arbitration Act for the time being in force shall apply to any such reference.

LETTER OF ACCEPTANCE

_____ (Date)

To _____ (Name and address of the Contractor)

Dear Sirs,

This is to notify that your Bid dated _____ for execution of the _____ (name of the contract and identification number as given in the Instructions to Bidders) for the Contract Price of Rupees _____ (_____) (amount in words and figures), as corrected and modified in accordance with the Instructions to Bidders is hereby accepted by our agency.

We accept/do not accept that _____ be appointed as the Adjudicator**. You are hereby requested to furnish Performance Security, in the form detailed in Para 34.1 of ITB for an amount equivalent to Rs. _____ within 14 days of the receipt of this letter of acceptance valid up to 28 days from the date of expiry of defects Liability Period i.e. up to _____ and sign the contract, failing which action as stated in Para 34.3 of ITB will be taken.

Yours faithfully,

Authorized Signature
Name and title of Signatory
Name of Agency

*Delete “corrected and” or “and modified” if only one of these actions applies. Delete as corrected and modified in accordance with the Instructions to Bidders, if corrections or modifications have not been affected.

**To be used only if the Contractor disagrees in his Bid with the Adjudicator proposed by the Employer in the “Instructions to Bidders”.

AGREEMENT

This agreement made the day of between the Executive Engineer, P.W.D., Namsai Division, [hereinafter called "The Employer"] and (name and address of contractor) hereinafter called "the Contractor" of the other part.

Whereas the Employer is desirous that the Contractor execute _____
(name and identification number of Contract)[hereinafter called "the works"] and the Employer has accepted the Bid of the Contractor for the execution and completion of such Works and the remedying of any defects therein, at a cost of Rs. (Rupees _____) only.

NOW THIS AGREEMENT WITNESSETH as follows:

1. In this Agreement, words and expressions shall have the same meanings as are respectively assigned to them in the conditions of Contract hereinafter referred to and they shall be deemed to form and be read and construed as part of this Agreement.
2. In consideration of the payments to be made by the Employer to the Contractor as hereinafter mentioned, the Contractor hereby covenants with the Employer to execute and complete the works and remedy any defects therein in conformity in all aspects with the provisions of the contract.
3. The Employer hereby covenants to pay the Contractor in consideration of the execution and completion of the works and the remedying the defects wherein Contract Price or such other sum as may become payable under the provisions of the Contract at the times and in the manner prescribed by the Contract.
4. The following documents shall be deemed to form and be ready and construed as part of this Agreement viz.
 - (i) Letter of Acceptance,
 - (ii) Notice to proceed with the works,
 - (iii) Contractor's Bid
 - (iv) Condition of Contract: General and Special,
 - (v) Contract Data,
 - (vi) Additional condition,
 - (vii) Drawings,
 - (viii) Bill of Quantities and
 - (vii) Any other documents listed in the Contract Data as forming part of the Contract.

In witnessed whereof the parties there to have caused this agreement to be executed the day and year first before written.

The common seal of
was hereunto affixed in the presence of :

Signed, Sealed and delivered by the said Chief Engineer, Eastern Zone PWD, and

In the presence of.....

Binding Signature of Employer

Binding Signature of Contractor

ISSUE OF NOTICE TO PROCEED WITH THE WORK

_____ (date)

To

_____ (Name and address of the Contractor)

Dear Sirs,

Pursuant to your furnishing the requisite security as stipulated in ITB Clause 34.1 and signing of
the Contract for the construction of
_____ at a Bid Price of
Rs _____ .

You are hereby instructed to proceed with the execution of the said works in accordance with the contract documents.

Yours faithfully,

Executive Engineer,
Tezu Division, PWD, AP
Tezu

UNDERTAKING

I, the under signed do hereby undertake that our firm M/s _____ agree to abide by this bid for a period of _____ days after the deadline date fixed for receiving the same and it shall be binding on us and may accepted at any time before the expiration of that period.

(Signed by an Authorized Officer of the Firm)

Title of Officer

Name of Firm

Date

Government of India
Ministry of Road Transport & Highways
(PIC Zone)

Y6

130.79

Transport Bhavan,
No. 1, Parliament Street,
New Delhi-110 001

No. RW/NH-24035/4/2008-P&M/PIC documents Dated the 27th November, 2009

To

as per this circular, and also *Borbo*

The Secretaries and Engineers-in-Chief/Chief Engineers (National Highways), State Public Works Departments, Union Territories (dealing with National Highways and other Centrally Financed Schemes); Director General (Works), Central Public Works Department; Director General Border Roads; The Chairman, National Highways Authority of India; Regional Officers/ Engineer Liaison Officers of MoRTH

Subj: Guidelines regarding procedures to be adopted for invitation of tenders and qualification of Contractors for execution of Road and Bridge works on National Highways and Centrally Financed Schemes - Modifications in the procedures.

Sir,

With developmental activities on National Highways having increased manifolds in recent years, the need for building capacity in the construction industry has come in sharp focus, particularly in the small and medium segment. One of the handicaps in the area is complete bar on participation of Joint Ventures for projects costing upto Rs. 100 crore as per the existing bidding procedure. It has been decided after careful consideration to permit joint ventures to participate in bids for projects costing more than Rs. 25 crore in all States other than North Eastern Region and J&K, where this threshold shall be Rs. 15 crore, subject to conditions contained in this circular.

2. It has also been experienced that many contracts face problems due to poor cash flow of the contractors. Even though the prevailing bidding procedures insist upon the contractors demonstrating the evidence of access to 10% of the project cost, the poor cash flow of contractors continues to affect the progress of the projects. It has, therefore, been decided that notwithstanding the existing provision, a financial partner in the Joint Venture (JV), who need not have any technical qualification but should pitch in with financial support to the JV, may be permitted. Member(s) of the JV, other than the financial member, should collectively meet all the experience requirements.

3. It has also been observed that pre-qualification process as per existing guidelines consumes considerable time. It has, therefore, been decided that two stage bidding process (prequalification in the first stage) shall be adopted only for projects costing Rs. 100 crore and above. Accordingly, single stage bidding process under two cover system (technical bid and financial bid) shall henceforth be followed for all projects costing between Rs. 5 crore and Rs. 100 crore. It may, however, be ensured that before the date fixed for opening of the financial bids, those bidders, who do not meet the qualification criteria and therefore are not eligible for consideration of their financial offer, are intimated about their non-eligibility and requested for collection of their sealed financial bid envelope.

4. In view of the above, the following existing circulars of the Ministry as well as the Standard Bidding Document circulated vide circular No. RW/NH-24020/2/99-PIC dated the 4th September, 2000 shall stand amended as follows: -

(i) Prequalification of contractors (circular no. RW/NH-37011/9/98-DO.I dated the 10th June, 1998)

Para 2.6 and 2.7 of the document (Invitation for Prequalification) enclosed with above circular shall be substituted by new para 2.6 and 2.7 as per Annex I.



B - Value at current price level of the existing commitments and ongoing works to be completed during the next _____ years (period of completion of works for which bids are invited); and

N - Number of years prescribed for completion of the works for which the bids are invited.

Note: In case of a Joint Venture, the available bid capacity will be applied for each partner to the extent of his proposed participation in the execution of the works.

2.6.10. Disqualification

Even though the Applicants meet the above criteria, they are subject to be disqualified if they have:

- made misleading or false representation in the form, statements submitted; and/or
- Records of poor performance such as abandoning the work, rescinding of contract for which the reasons are attributable to the non-performance of the contractor; consistent history of litigation awarded against the Applicant or financial failure due to bankruptcy. The rescinding of contract of a joint venture on account of reasons other than non-performance, such as Most Experienced partner of joint venture pulling out, court directions leading to breaking up of a joint venture before the start of work, which are not attributable to the poor performance of the contractor will, however, not affect the qualification of the individual partners.

2.7. JOINT VENTURE

2.7.1. Joint ventures must comply with the following requirements:

(a) Following are the minimum qualification requirements:

- (i) The lead partner shall meet not less than 50 per cent of all the qualifying criteria given in para 2.6.3 & 2.6.6 above. The joint venture must collectively satisfy the criteria of para 2.6.3 & 2.6.6 above. The experience of the other joint venture partners shall be considered if it is not less than 30 per cent of the qualifying criteria given in para 2.6.3 & 2.6.6 above. However, in case one of the joint venture partners is proposed to be included primarily to provide financial strength to the joint venture, such joint venture partner shall have to commit to provide liquidity support to the project to the extent of 10 per cent of the value of the contract.
- (ii) The joint venture must satisfy collectively the criteria of para 2.6.4 and 2.6.5 above for which purpose the relevant figures for each of the partners shall be added together to arrive at the joint venture's total capacity. Individual members must each satisfy the requirements of para 2.6.7 & 2.6.8 above.

(b) The formation of a joint venture after prequalification, any change in a pre-qualified joint venture, will be subject to the written approval of the Employer prior to the deadline for submission of bids. Such approval shall be denied if (i) partners withdraw from a joint venture and the remaining partners do not meet the qualifying requirements; (ii) the new partners to a joint venture are not qualified individually or as another joint venture; or (iii) in the opinion of the Employer, a substantial reduction in competition may result.

(c) Bid shall be signed so as to legally bind all partners, jointly and severally, and shall be submitted with a copy of the joint venture agreement providing the 'joint and several' liability with respect to the contract.

2.7.2. Qualification of a joint venture does not necessarily qualify any of its partners individually or as a partner in any other joint venture. In case of dissolution of a joint venture, each one of the constituent firms may qualify if they meet all the qualification requirements, subject to the written approval of the Employer.

6/8

Annexure-I

Minimum key personnel for the project

Sl. No.	Personnel	Qualification	LCIT size			
			Rs. 50 Million	Rs. 51-200 Million	Rs. 201-500 Million	Rs. 501-1000 Million & above
1.	Project Manager	B.E. Civil + 10 Years Exp.	1	1 No.	1 No.	1 No.
2.	Site Engineer	B.E. Civil + 5 Years Exp.	1	2 No.	4 Nos.	6 Nos.
3.	Plant Engineer	B.E. Mech. + 3 Years Exp. Or Dip. Mech. + 7 Years Exp.	1	1 No.	1 No.	2 Nos.
4.	Quantity Surveyor	B.E. Civil + 7 Years Exp. Or Dip. Civil + 7 Years Exp.	1	1 No.	1 No.	1 No.
5.	Soil & Material Engineer	B.E. Civil + 7 Years Exp. Or Dip. Civil + 7 Years Exp.	1	1 No.	1 No.	1 No.
Total			5 Nos.	6 Nos.	8 Nos.	12 Nos.

Annexure-II

List of Plant & Equipment to be Deployed on Contract Work

Sl. No.	Type of Equipment	Maximum Age as on	Up to Rs. 50 million	Rs. 51-200 Million	Rs. 201-500 Million	Rs. 501-1000 Million & above
1.	Tipper Trucks	5-7	6	10	15	20
2.	Motor Grader	5	2	2	3	4
3.	Dozer	5	1	1	1	2
4.	Front end Loader	5	2	2	2	4
6.	Vibratory Roller	5	2	2	2	4
7.	H&M Paver with Electronic	5	1	1	1	2
8.	Paver Finisher with Electronic Sensor	5	1	1	1	2
9.	Water Tanker	5	3	3	4	5
10.	Blowdown Sprayer	5-7	1	1	1	2
11.	Tandem Roller	5	1	1	1	1
12.	Concrete Mixers with Integral Weigh Batching facility	5	2	2	1	2
13.	Concrete Batching and Mixing Plant (Minimum Capacity - 15 m ³ /hour)	5	-	-	1	1
14.	Concrete paver capable of paving 7.5m width in one single pass including all accessories. Such as automatic dowel bar inserter, integral vibratory system and electronic sensors ancillary equipment for applying curing compound, joint cutting etc.	5	-	-	-	1
15.	Concrete Batching and Mixing plant with automatic control (minimum 100 cum/hour)	5	-	-	-	1
Total			24	28	35	54

SPECIAL CONDITIONS AMENDMENT

120 (A)

1. Arrangement of inner line permit:-

The work site falls within the inner line area demarcation of Government of India and the contractor residing outside the inner line area shall have to obtain inner line permit for entering the area / worksite for himself as well as for the workers being brought from the outside the inner line demarcation from designated officers for issue of inner line permit by Government of Arunachal Pradesh. The contractor shall have to pay the prescribed fees fixed by Government of Arunachal Pradesh payable for the issue of inner line permit by the competent authorities for which no extra claimed shall be entertained.

2. Payment of Royalty and Monopoly fee for use forest product :-

Contractor shall have to pay royalty and monopoly fee for collection of forest produce and minor mineral products at the prescribed rates to the department of Forest, department of geology and Mining of Government of Arunachal Pradesh extraction of forest and minor mineral products. All such charges shall be deemed to have covered in the rates quoted by the contractor. No extra claims on account of such payment shall be entertained during the currency of the contract. In case the contractor fails produce the requisite challan / permit from the designated officers of the concern department in support of having paid royalty and monopoly fees, necessary recovery shall be affected from the contractor's bills at the prescribed rate.

3. Recovery of GST:-

The recovery rate of GST @ 18% on the cost of work done.

4. Payment of Cess for building and other construction worker's welfare:-

As per Worker's Welfare Cess Act 1996, 1% Cess on the gross amount of Contractor's bill of building and other construction works shall be recovered.

5. Income Tax deduction at source:-

Income tax with surcharge and cess at prescribed rate shall be deducted on the gross value of contractor's bill.

6. Defect liability period shall be 1 (one) year from the date of completion of the project.

7. The enlistment of the contractors should be valid on the last date of sale of tender. In case both the last date of receipt of application and sale of tenders are extended, the enlistment of contractor should valid on either of the two dates i.e. original sale of tender or on the extended date of sale of tenders.

8. The work is estimated to cost **Rs.4390.00 Lakhs**. This estimate, however, is given merely as a rough guide.

120 Ma

Blank

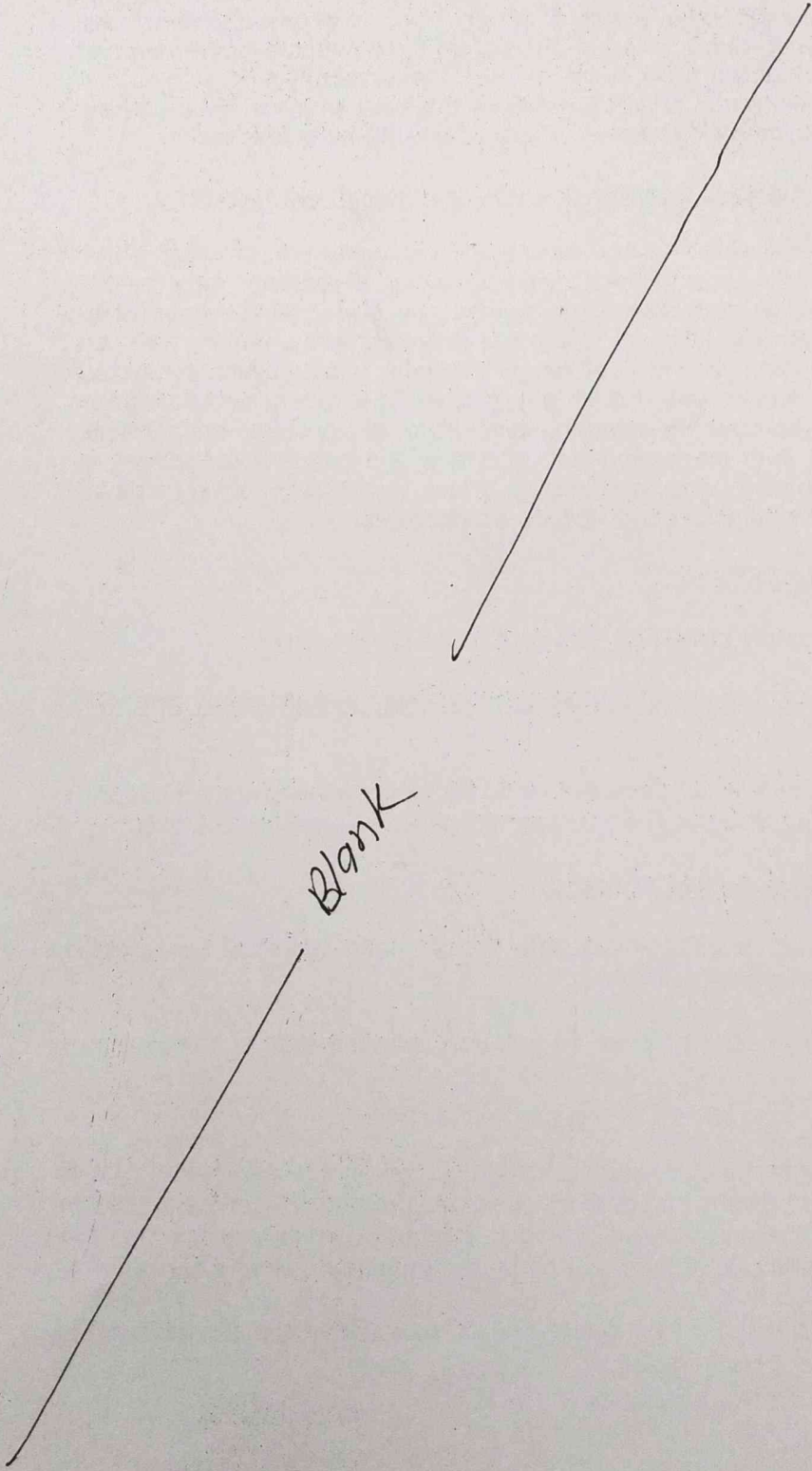

9.

~~Tenders will be issued to eligible contractors provided they produce definite proof from the appropriate authority, which shall be to the satisfaction of competent authority, of having satisfactorily completed similar works of magnitude specified below :-~~

10.

~~**Criteria of eligibility for issue of tender documents.**~~

~~10.1 Conditions for Non-PWD contractors only, if tenders are also open to non-PWD contractors.~~

~~**10.2 For works estimated to cost up to Rs. 20 Crore.**~~

~~Three similar works each of value not less than 40 % of estimated cost or two similar work each of value not less than 50 % of estimated cost or one similar work of value not less than 80 % of estimated cost (rounded to nearest Rs.. 10 lacs) in last 7 years ending last day of the month previous to the one in which the tenders are invited.~~

~~**Note:-** For works costing above Rs.5 crore but up to Rs. 20 crore, when tenders are open to non -PWD contractors also, then class II contractors of PWD shall also be eligible if they satisfied the eligibility criteria specified in 1.2.1 above.~~

~~**10.3 Criteria of eligibility for PWD as well as non-PWD contractors. For works estimated cost above Rs. 20 crore.**~~

11.

~~Three similar works each of value not less than 40 % of estimated cost or two similar work each of value not less than 60 % of estimated cost or one similar work of value not less than 80 % of estimated cost (rounded to nearest Rs.10 lacs) in last 7 years ending last day of the month previous to the one in which the tenders are invited.~~

~~The value of executed works shall be brought to current costing level by enhancing the actual value of work a simple rate of 7 % per annum, calculated from the date of completion to the last date of receipt of applications for tender.~~

12.

"I/we undertake and confirm that eligible work(s) has / have not been got executed through another contractor on back to back basis. Further that. If such a violation comes to the notice of department then I/we shall be debarred for tendering in PWD in future for ever. Also if such a violation comes to the notice of department before date of start of work the Engineer-in-charge shall be free to forfeit the entire amount of earnest money deposit /performance guarantee"

13. Agreement shall be drawn with the successful tenderer on prescribed Form No. CPWD 7/8 which is available as a Government of Arunachal Pradesh Publication.

E-Tender shall quote his rates as per various terms and conditions of the said form which will form part of the Agreement.

120(B)b

Blank

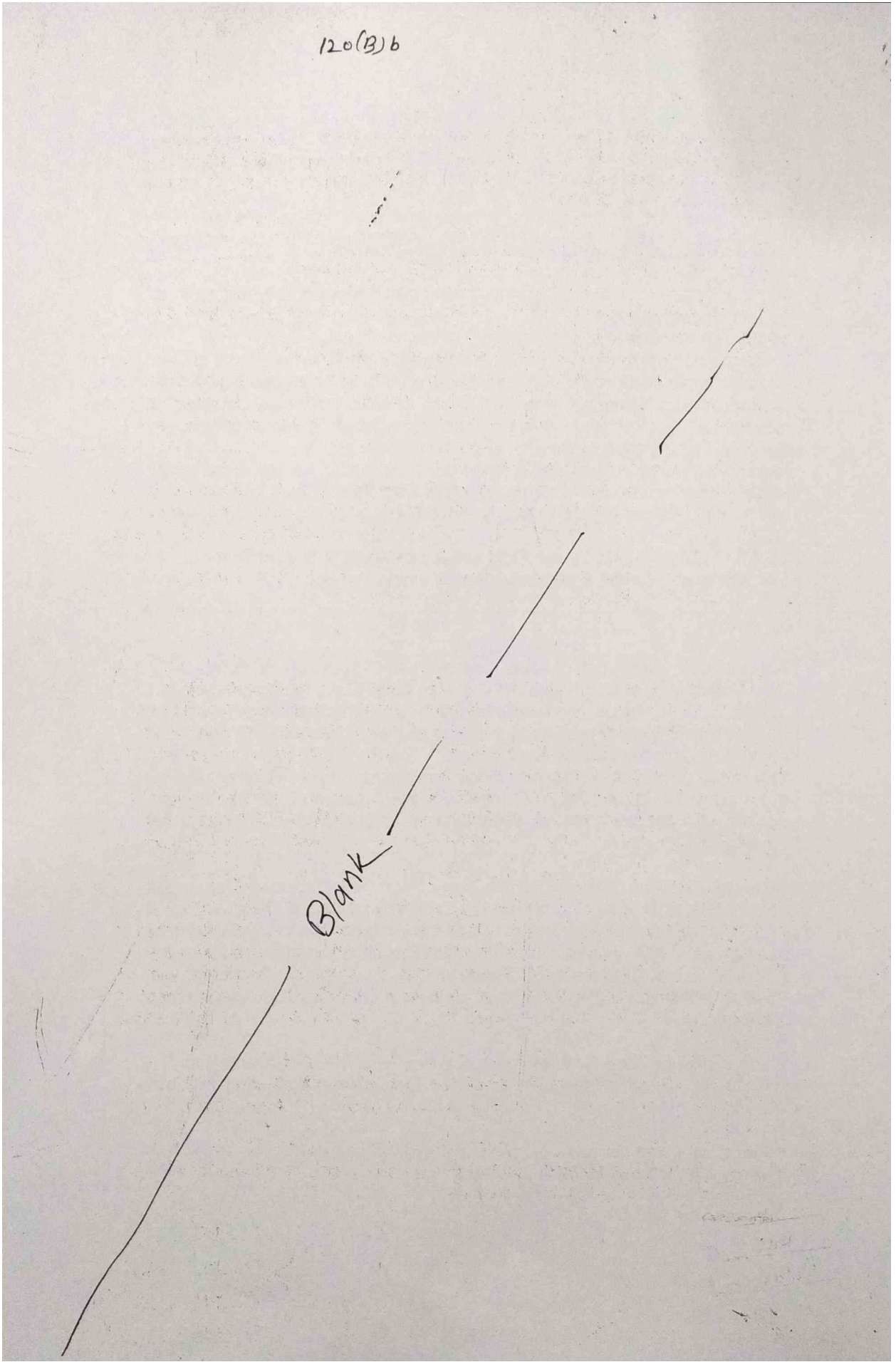

14. The time allowed for carrying out the work will be **24 months** from the date of start as defined in Schedule 'F' or from the first date of handing over of the site, whichever is later, in accordance with the phasing, if any, indicated in the tender documents.
15. The site for the work is available.
16. (i) Tenders shall be accompanied with Earnest money of **Rs 43.90 Lakhs for APST & 53.90 Lakhs for Non-APST contractor** in form of Receipt Treasury Challan/Deposit at Call receipt of a scheduled bank/fixed deposit receipt of a scheduled bank issued in favour of **Executive Engineer, Tezu PW Division, Tezu.**

~~The tender and the earnest money shall be placed in separate sealed envelopes each marked tender and Earnest money respectively. Both the envelopes shall be submitted together in another sealed envelope with the name of work and due date of opening written on envelopes, which will be received by the Executive Engineer, Changlang PW Division, Changlang up to 3.00 PM on and will be opened by him or his authorized representative in his office on the same day at 3.30 PM. The envelope marked "Tender" of only those tenderers shall be opened, whose earnest money, placed in the other envelope, is found to be in order.~~

17. The contractor whose tender is accepted will be required to furnish performance guarantee of 5% (Five percent) of the tendered amount within the period specified in Schedule 'F'. This guarantee shall be in the form of cash (in case guarantee amount is less than Rs. 10,000/- or Deposit at call receipt of any scheduled bank/ Banker's cheque on any scheduled bank/ Demand Draft of any scheduled bank/ pay order of any scheduled bank (in case guarantee amount is less than Rs. 100000/-) or Govt. securities or fixed deposit receipt or guarantee Bonds of any scheduled bank or the State bank of India in accordance with the prescribed form. In case the contractor fails to deposit the said performance guarantee within the period as indicated in schedule 'F', including the extended period if any, the earnest money deposited by the contractor shall be forfeited automatically without any notice to the contractor. The earnest money deposited along with tender shall be returned after receiving the aforesaid performance guarantee.
18. The competent authority on behalf of Governor of Arunachal Pradesh does not bind itself to accept the lowest or any other tender and reserves to itself the authority to reject any or all of the tenders received without the assignment of any reason. All tenders in which any of the prescribed conditions are not fulfilled or any condition including that of conditional rebate is put forth by the tenderers shall be summarily rejected.
19. The intending Tenderers are advised to visit the site of work at his own cost and examine it and its surroundings to collect himself all information that he consider necessary for proper assessment of the prospective assignment.
20. The competent authority on behalf of Governor of Arunachal Pradesh reserves to himself the right of accepting the whole or any part of the tender and the tenderer shall be bound to perform the same at the rate quoted.

20(1)c

Blank

21. Canvassing whether directly or indirectly, in connection with tenders is strictly prohibited and the tenders submitted by the contractors who resort to canvassing will be liable to rejection.
22. The contractor shall not be permitted to tender for works in the PWD Circle (responsible for award and execution of contracts) in which his near relative is posted as Divisional Accountant or as an officer in any capacity between the grades of Superintending Engineer and Assistant Engineer (both inclusive). He shall also intimate the names of persons who are working with him in any capacity or are subsequently employed by him and who are near relatives to any gazetted officer in the Public works Department or in the Ministry of Urban Development. Any breach of this condition by the contractor would render him liable to be removed from the approved list of contractors of this Department.
23. No Engineer of gazetted rank or other Gazetted officer employed in Engineering of Administrative duties in an Engineering Department of the Government of Arunachal Pradesh is allowed to work as a contractor for a period of two years after his retirement from Government service, without the previous permission of the Government of Arunachal Pradesh in writing. This contract is liable to be cancelled if either the contractor or any of his employees is found any time to be such a person who had not obtained the permission of the Government of Arunachal Pradesh as aforesaid before submission of the tender or engagement in the contractor's service.
24. The tender for the works shall remain open for acceptance for a period of thirty/forty/sixty/ninety 120 days from the date of opening of tenders/ Ninety days from the date of opening of financial bid incase tenders are invited on 2/3 envelop system/ one hundred twenty days from the date of opening of technical bid in case bids are invited on 3 bid system for specialized work (strike out as the case may be). If any tenderer withdraws his tender before the said period or issue of letter of acceptance, whichever is earlier or makes any modifications in the terms and conditions of the tender which are not acceptable to the Department, then the Government shall, without prejudice to any other right or remedy, be at liberty to forfeit 50% for the said earnest money as aforesaid. Further the tenderer shall not be allowed to participate in the re-tendering process of the work.
25. This notice inviting tender shall form a part of the contract documents. The successful Tenderer / contractor, on acceptance of his tender by the Accepting Authority, shall, within 15 days from the stipulated date of start of the work sign the contract consisting of: -
 - a) The notice inviting tender, all the documents including additional conditions specifications and drawings, if any, forming the tender as issued at the time of invitation of tender and acceptance thereof together with any correspondence leading thereto.
 - b) Form of Bid.
26. The Bidders will have to produce No Dues Certificate (NDC)/No Objection Certificate (NOC) from the Arunachal Pradesh State Co-Operative Apex Bank Ltd. Duly issued by the Managing Director Cum Chief Executive Officer, Itanagar in order to participate.

120 CD) d

B1927K

120 (E)
E01

27. The tender shall be governed by District Based Entrepreneurship Act No.Law/Legn-23/2020 dtd. 2nd Nov 2020.
28. Financial Bid will be opened after approval of Technical Bid.
29. Form of Bid to be mandatory signed by the contractor while submitting the tender, failing which it will be summarily rejected.
30. Mix design for bituminous concrete should be done as per specification mentioned in the schedule (i.e using crushed aggregates of specified grading, premixed with bituminous binder @5.4 to 5.6 % of mix and filler.)
31. In case of abnormally low rates, the cost difference of justified amount minus amount quoted shall be paid in Performance guarantee in addition to normal 5% performance guarantee before award of work mandatorily.
32. The detail working /action against milestone mentioned in bid document should be submitted along with performance guarantee and shall form part of agreement.
33.

The Technical and Financial bids shall be mandatorily in separate envelope and sealed, failure of which bid shall be rejected.
--
34. The financial bid of successful bidder shall be only opened.
35. Bidder shall inspect work site for understanding the working condition and justification of quantities given in BOQ and also the quarry site for availability of local materials.
36. The defect liability period of rectification of work shall be for at least 12(Twelve) months after expiry of the date of completion of work. The contractor shall carry out all defects during the said period failure which the security deposits shall be forfeited.
37. In no circumstances shall the contractor assign a sub contractor or any third party of holding a general power of attorney to operate the contract awarded to him failure which agreement shall be liable to be rescinded.

List of Documents to be submitted:

- I. Enlistment & subsequent re-validation order of Bidder.

120 (E)
E01

27. The tender shall be governed by District Based Entrepreneurship Act No.Law/Legn-23/2020 dtd. 2nd Nov 2020.
28. Financial Bid will be opened after approval of Technical Bid.
29. Form of Bid to be mandatory signed by the contractor while submitting the tender, failing which it will be summarily rejected.
30. Mix design for bituminous concrete should be done as per specification mentioned in the schedule (i.e using crushed aggregates of specified grading, premixed with bituminous binder @5.4 to 5.6 % of mix and filler.)
31. In case of abnormally low rates, the cost difference of justified amount minus amount quoted shall be paid in Performance guarantee in addition to normal 5% performance guarantee before award of work mandatorily.
32. The detail working /action against milestone mentioned in bid document should be submitted along with performance guarantee and shall form part of agreement.
33.

The Technical and Financial bids shall be mandatorily in separate envelope and sealed, failure of which bid shall be rejected.
--
34. The financial bid of successful bidder shall be only opened.
35. Bidder shall inspect work site for understanding the working condition and justification of quantities given in BOQ and also the quarry site for availability of local materials.
36. The defect liability period of rectification of work shall be for at least 12(Twelve) months after expiry of the date of completion of work. The contractor shall carry out all defects during the said period failure which the security deposits shall be forfeited.
37. In no circumstances shall the contractor assign a sub contractor or any third party of holding a general power of attorney to operate the contract awarded to him failure which agreement shall be liable to be rescinded.

List of Documents to be submitted:

- I. Enlistment & subsequent re-validation order of Bidder.

120 CE)
e

BLANK

120(R)

- II. Proof of Permanent address of Bidder.
- III. Affidavit for address of communication/ Office address, Contact Number, E-mail I D, FAX Number.
- IV. Certificates of Work Experience for similar nature of work for last 5 years along with award letter, completion certificate etc.
- V. Current income tax clearance / exemption certificate.
- VI. Certificate for ownership of T & P's with proof of age and possessed.
- VII. Certificate of Registration for GST and acknowledgement of upto date filed return.
- VIII. Certificate for Bank Solvency (40% of the tender value).
- IX. No dues certificate from Appex Co-operative Bank Ltd duly issued by the Managing Director Cum Chief Executive Officer, Itanagar.
- X. Financial turn over duly audited by Chartered Accountant for last 5 years.
- XI. Schedule Tribe certificate.
- XII. Aadhaar card.
- XIII. Pan Card.
- XIV. Bid Security /EMD.
- XV. Cost of Bid documents.

Signature of Executive Engineer,
Tezu Division, PWD, AP, Tezu
For & on behalf of Governor of Arunachal Pradesh

120(R)

- II. Proof of Permanent address of Bidder.
- III. Affidavit for address of communication/ Office address, Contact Number, E-mail I D, FAX Number.
- IV. Certificates of Work Experience for similar nature of work for last 5 years along with award letter, completion certificate etc.
- V. Current income tax clearance / exemption certificate.
- VI. Certificate for ownership of T & P's with proof of age and possessed.
- VII. Certificate of Registration for GST and acknowledgement of upto date filed return.
- VIII. Certificate for Bank Solvency (40% of the tender value).
- IX. No dues certificate from Appex Co-operative Bank Ltd duly issued by the Managing Director Cum Chief Executive Officer, Itanagar.
- X. Financial turn over duly audited by Chartered Accountant for last 5 years.
- XI. Schedule Tribe certificate.
- XII. Aadhaar card.
- XIII. Pan Card.
- XIV. Bid Security /EMD.
- XV. Cost of Bid documents.

Signature of Executive Engineer,
Tezu Division, PWD, AP, Tezu
For & on behalf of Governor of Arunachal Pradesh

12c(F) f

Blank

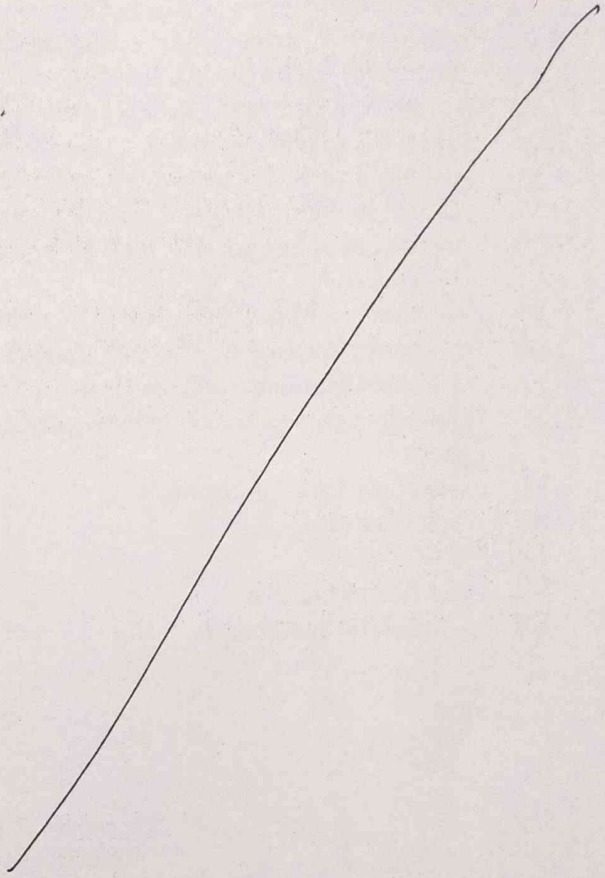
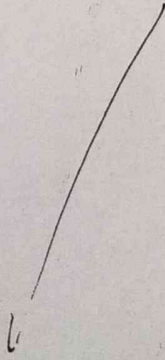

**SECTION-9
DRAWINGS**

BLANK

TEZU TOWN SHIP ROAD MAP

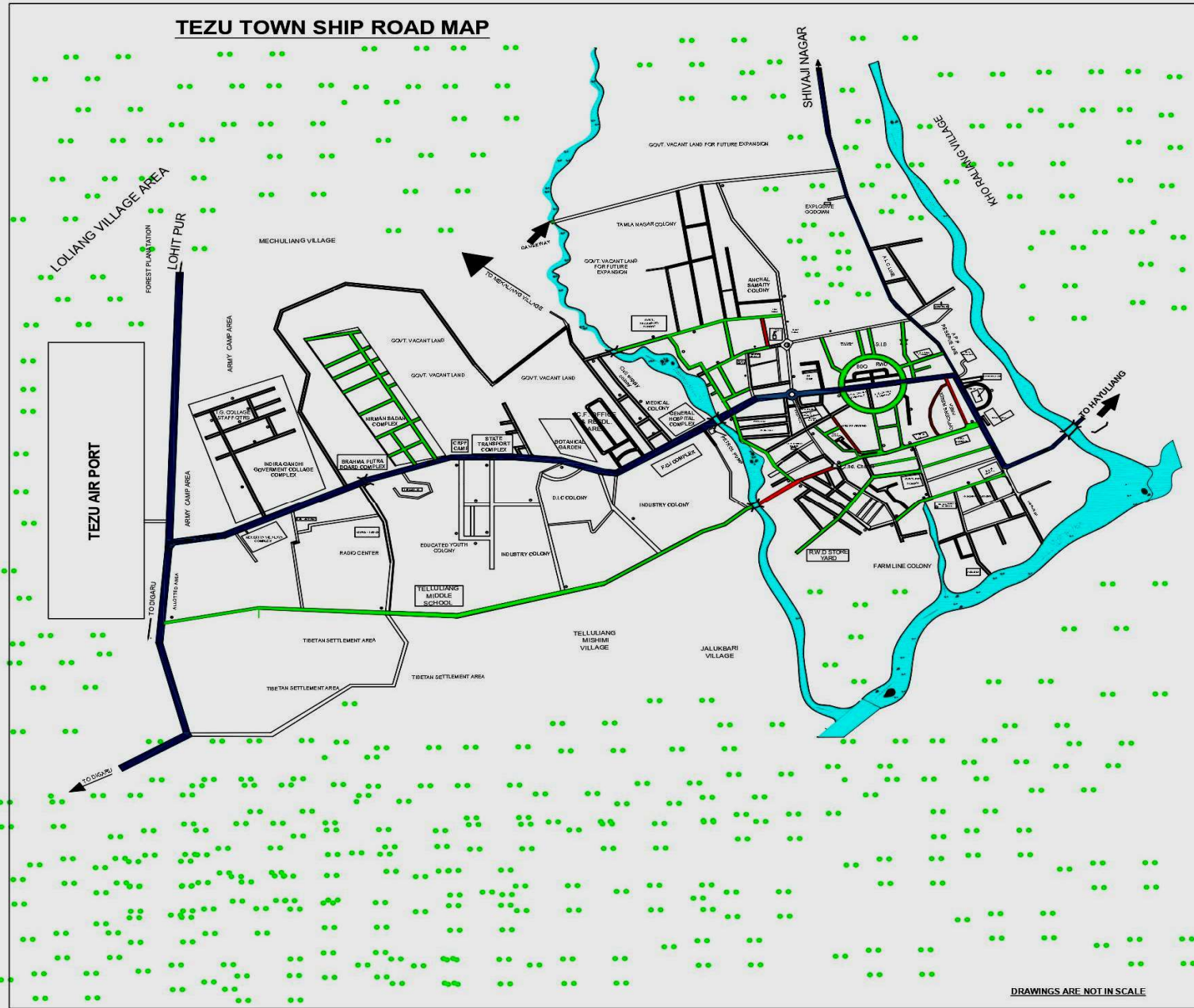







DRAWINGS ARE NOT IN SCALE

GOVERNMENT OF ARUNACHAL PRADESH
PUBLIC WORKS DEPARTMENT
OFFICE OF THE EXECUTIVE ENGINEER
TEZU DIVISION : LOHIT DISTRICT : A.P



INDEX

-  B.R.O ROAD
-  RIVER, STREAM,
-  PROPOSED ROAD FOR THIS SCHEME
-  FOREST AREA
-  OTHER EXISTING ROAD IN TEZU T/SHIP
-  PROPOSED DOUBLE LANE ROAD
-  PROPOSED INTERMEDIATE LANE ROAD

DETAILS OF ROADS		
Sr No.	Name of Road	Length
Double lane road		
1	Gandhi Chowk to Fish Market	0.225
2	Denning bridge to Medical colony and Civil supply colony	1.445
3	BRTF road to Club road via Jublee ground	0.467
4	Officers colony road	0.680
5	Ind Charali to Denning Nallah via Minister charali	0.518
Total (A) =		3.385
Intermediate lane		
6	Main Market to Kristiko market road via Co-operate.	0.195
7	Fish market Tinali to Denning bridge via Sec. School	0.808
8	Ramayan Hotel to Secondary school road	0.595
9	Fish market to Bypass road	0.705
10	Farm line Charali to Medical tinali via Minister line	1.250
11	Ind Charali to BRTF road via Town club	0.805
12	PWD Enquiry to Farm line road via Higher secondary school	0.870
13	H.S. School to Range office	0.635
14	Internal roads to Transit Hostel, Circuit House, Officers club, D.C. Bunglow & S.P. Bunglow	0.650
15	BRTF road tinali (Near Dangoria) to Amik-Matal Colony	1.140
16	Medical charali to Secondary school staff copmplex road	0.870
17	Ramayan Hotel to Tamadu festival ground charali	0.205
18	Back side of mandir complex road	0.177
19	BRTF road to D.C. office and Internal roads	0.990
20	PWD colony road (Back side of Jublee ground)	1.280
21	Internal roads of Nirman sadan	3.250
22	S.B.I. Colony roads	0.660
23	Butcher line road	0.400
24	Pinku Market intern roads.	0.490
25	Road from Church Tinali near Denning Nallah bridge to Lana camp charali	1.700
26	BSNL, SIB & Doonarsan Kendra colony roads	0.920
27	Road from NH-13 near Petrol pump to Telluliang village (Near Baptist Church)	0.625
Total (B) =		19.220
G/Total (A) + (B) =		22.575

Asstt. Engineer Tezu Sub-Division, FWD, Tezu, AP. Asstt. Surveyor of Works Tezu Division, FWD, Tezu, AP. Executive Engineer Tezu PW Division, Tezu, AP.

BLANK

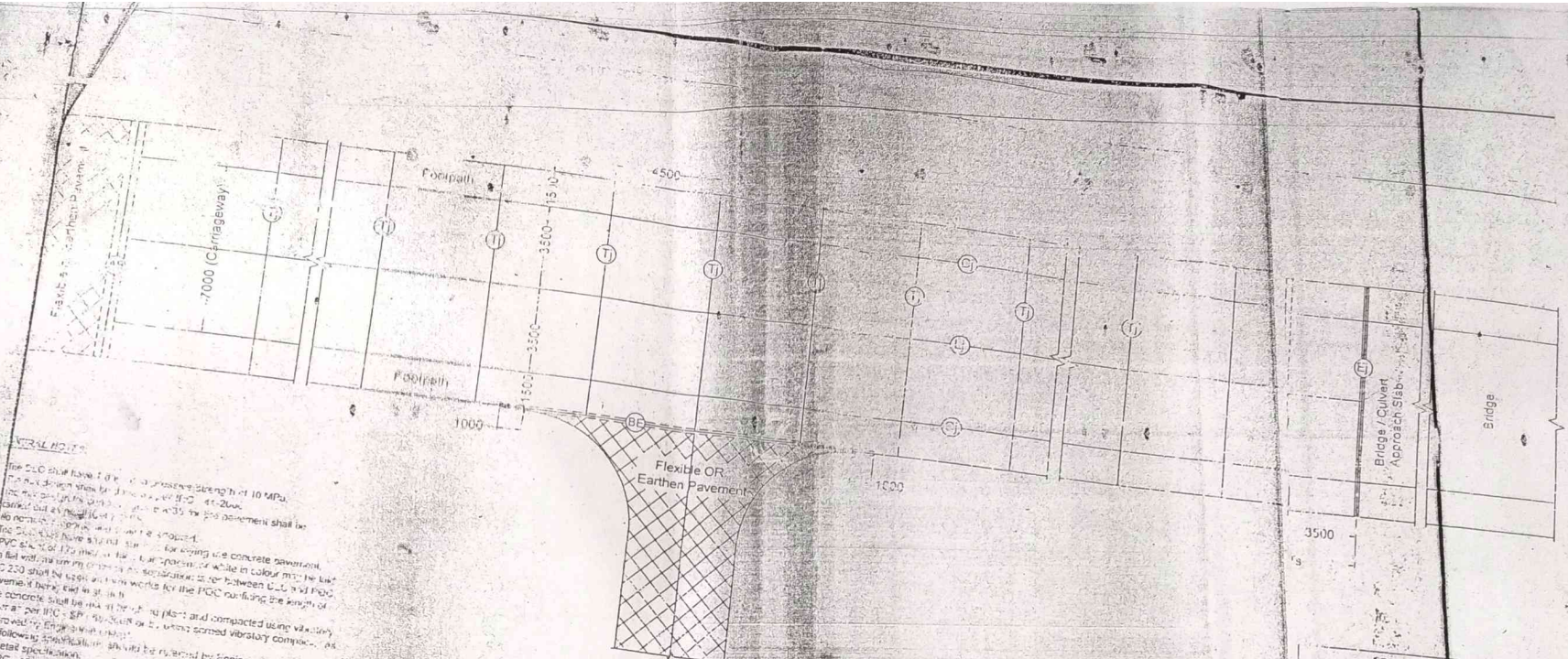

GENERAL NOTES

The S.C.C. shall have a 28 days compressive strength of 10 MPa.
 The maximum depth shall be 150 mm for 90-100-200.
 The maximum depth shall be 150 mm for 90-100-200.
 The concrete shall be placed and compacted using vibratory
 approved by Engineer-in-charge.
 The concrete shall be placed and compacted using vibratory
 approved by Engineer-in-charge.
 The following specifications should be followed by Engineer-in-charge
 for detail specifications.

- a) IRC - 15 - 2011
- b) IRC - SP - 64 - 2003
- c) IRC - 44 - 2004
- d) IRC - 58 - 2011
- e) MORTH specification for Road and Bridge works.

Grade of concrete in Footpath is M15.
 For details of Reinforced Earthwork Layout, authorized manufacturer
 may be referred.
 All dimensions are in mm (unless noted)

TYPICAL PLAN OF PAVEMENT

ABBREVIATIONS	
Lj	LONGITUDINAL JOINT
Ej	EXPANSION JOINT
Cj	CONSTRUCTION JOINT
Tj	TRANSVERSE JOINT
T5	TERMINAL SLAB
f_2C	PAVEMENT QUALITY CONTROL
DLC	DRY LEAN CONCRETE
AB	ANCHOR BEAM
BE	BEAMED EDGE

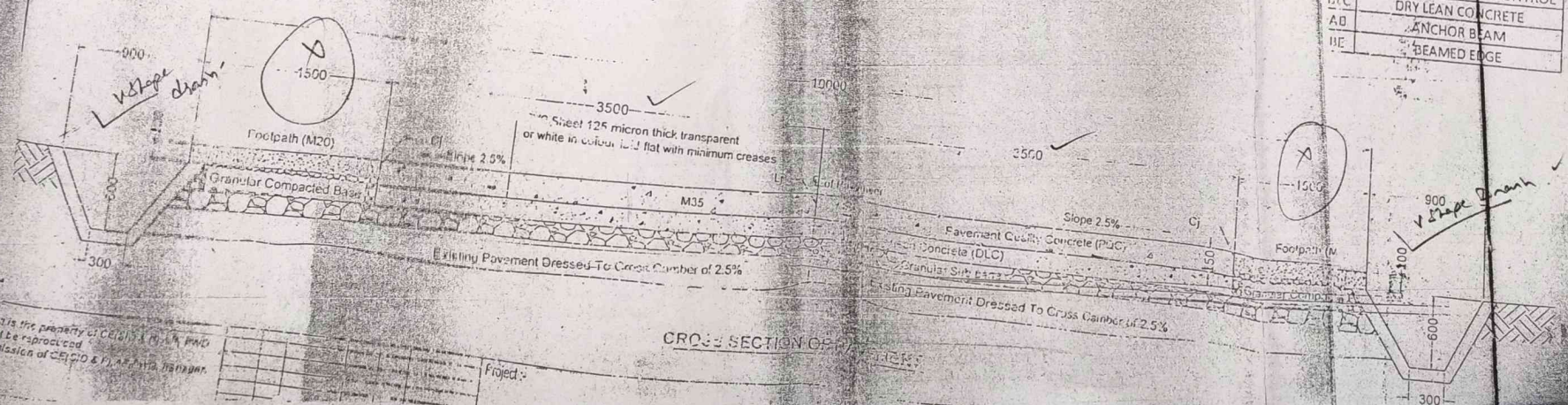

CROSS SECTION OF PAVEMENT

This is the property of CECID & P. Ltd. and
 it is reproduced
 without the permission of CECID & P. Ltd. Manager.

Project :

BLANK

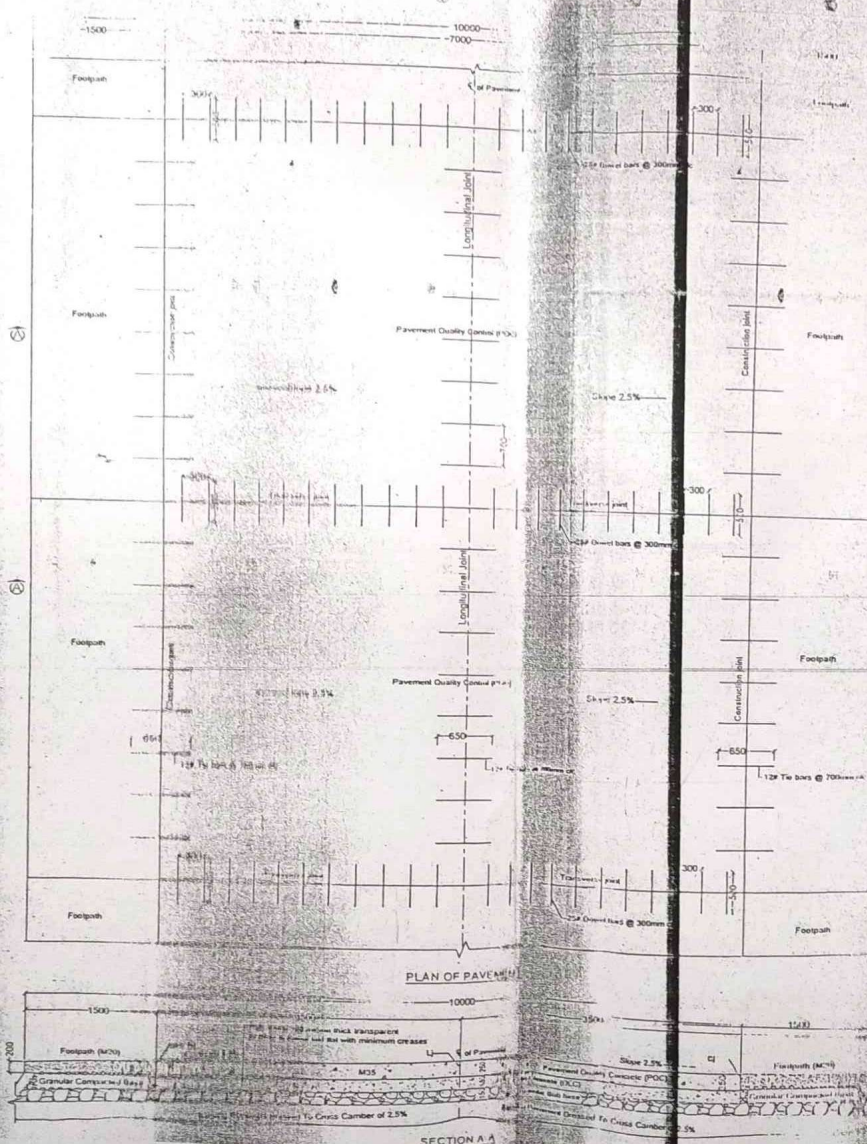

GENERAL NOTES:

1. The D.L.C. shall have 7 days before the start of work.
2. The mix design for concrete shall be as per IRC-44.
3. The D.L.C. shall have concrete PQC of 125 mm nominal maximum aggregate size.
4. MC 250 shall be used as per the provisions being laid down.
5. The concrete shall be 150 mm thick.
6. For details of the pavement structure, refer to the following specifications:
 - a) IRC - 15 - 2011
 - b) IRC - SP - 46 - 2004
 - c) IRC - 44 - 2004
 - d) IRC - 58 - 2011
 - e) MORTH Specifications
7. The concrete shall be 150 mm thick.
8. For details of the pavement structure, refer to the following specifications:
 - a) IRC - 15 - 2011
 - b) IRC - SP - 46 - 2004
 - c) IRC - 44 - 2004
 - d) IRC - 58 - 2011
 - e) MORTH Specifications
9. For details of the pavement structure, refer to the following specifications:
 - a) IRC - 15 - 2011
 - b) IRC - SP - 46 - 2004
 - c) IRC - 44 - 2004
 - d) IRC - 58 - 2011
 - e) MORTH Specifications

BLANK

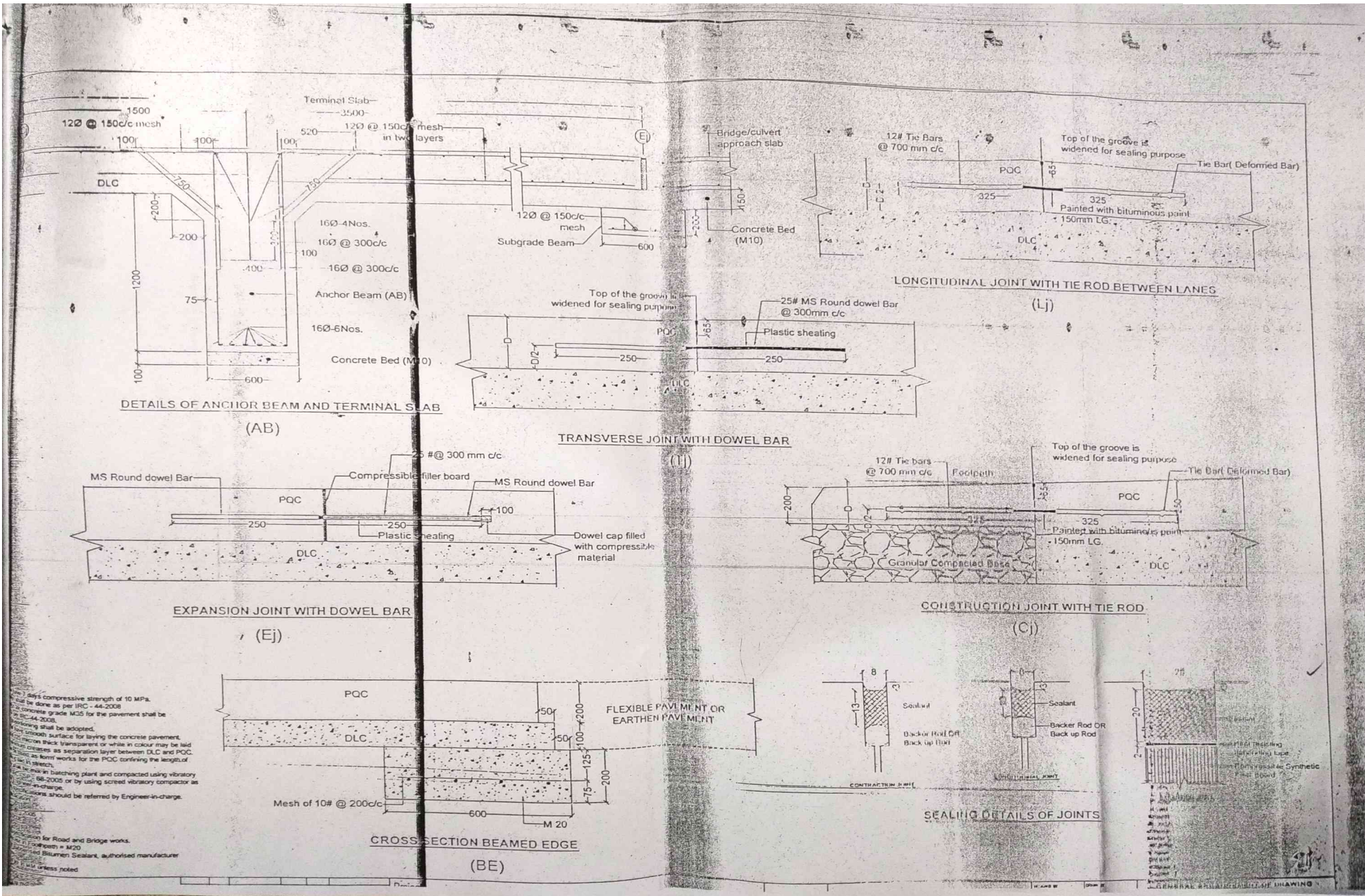

1. The concrete shall have a minimum compressive strength of 10 MPa.
 2. The concrete shall be done as per IRC - 44-2008
 3. The concrete grade M35 for the pavement shall be as per IRC-44-2008.
 4. The curing shall be adopted.
 5. The surface shall be smooth for laying the concrete pavement.
 6. The concrete shall be transparent or white in colour may be laid in thin courses as separation layer between DLC and PQC.
 7. The concrete shall be done as form works for the PQC confining the length of the joint in stretch.
 8. The concrete shall be done in batching plant and compacted using vibratory roller or by using screed vibratory compactor as per IRC-44-2008.
 9. The concrete shall be done as per IRC-44-2008.
 10. The concrete shall be done as per IRC-44-2008.
 11. The concrete shall be done as per IRC-44-2008.
 12. The concrete shall be done as per IRC-44-2008.
 13. The concrete shall be done as per IRC-44-2008.
 14. The concrete shall be done as per IRC-44-2008.
 15. The concrete shall be done as per IRC-44-2008.
 16. The concrete shall be done as per IRC-44-2008.
 17. The concrete shall be done as per IRC-44-2008.
 18. The concrete shall be done as per IRC-44-2008.
 19. The concrete shall be done as per IRC-44-2008.
 20. The concrete shall be done as per IRC-44-2008.

1. The concrete shall be done as per IRC-44-2008.
 2. The concrete shall be done as per IRC-44-2008.
 3. The concrete shall be done as per IRC-44-2008.
 4. The concrete shall be done as per IRC-44-2008.
 5. The concrete shall be done as per IRC-44-2008.
 6. The concrete shall be done as per IRC-44-2008.
 7. The concrete shall be done as per IRC-44-2008.
 8. The concrete shall be done as per IRC-44-2008.
 9. The concrete shall be done as per IRC-44-2008.
 10. The concrete shall be done as per IRC-44-2008.
 11. The concrete shall be done as per IRC-44-2008.
 12. The concrete shall be done as per IRC-44-2008.
 13. The concrete shall be done as per IRC-44-2008.
 14. The concrete shall be done as per IRC-44-2008.
 15. The concrete shall be done as per IRC-44-2008.
 16. The concrete shall be done as per IRC-44-2008.
 17. The concrete shall be done as per IRC-44-2008.
 18. The concrete shall be done as per IRC-44-2008.
 19. The concrete shall be done as per IRC-44-2008.
 20. The concrete shall be done as per IRC-44-2008.

BLANK

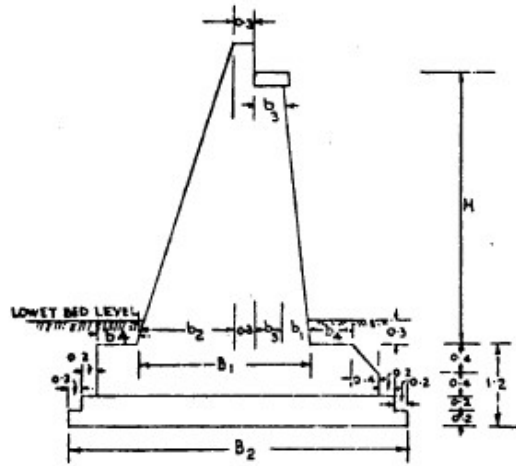

SECTION OF ABUTMENT

TABLE OF DIMENSIONS FOR ABUTMENT

SPAN	6 M AND 5 M					4 M, 3 M, 2 M, 1.5 AND 1 M					
	2.0 M	2.5 M	3.0 M	3.5 M	4.0 M	1.5 M	2.0 M	2.5 M	3.0 M	3.5 M	4.0 M
H	0.2	0.25	0.3	0.35	0.4	0.15	0.2	0.25	0.3	0.35	0.4
b ₁	0.6	0.85	1.0	1.2	1.4	0.5	0.7	0.95	1.1	1.25	1.4
b ₂	0.4	0.4	0.4	0.4	0.4	0.3	0.3	0.3	0.3	0.3	0.3
b ₃	-	0.1	0.2	0.4	0.6	-	-	0.1	0.2	0.3	0.5
B ₁	1.5	1.8	2.0	2.25	2.5	1.25	1.5	1.8	2.0	2.2	2.4
B ₂	2.7	3.2	3.6	4.25	4.9	2.45	2.7	3.2	3.6	4.0	4.6

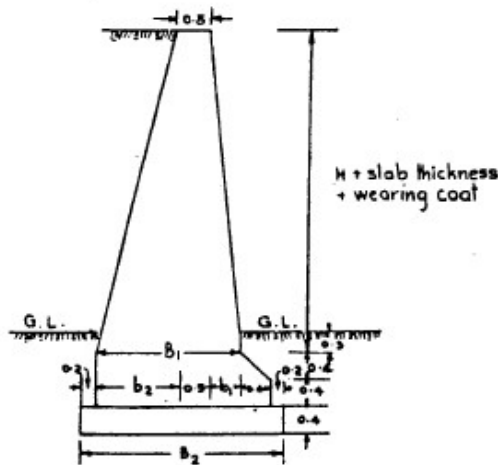

WING WALL SECTION AT HIGH END

SPAN	UP TO 2 METRES					3 METRES					4 METRES					5 METRES					6 METRES								
	1.50	2.00	2.50	3.00	3.50	4.00	1.50	2.00	2.50	3.00	3.50	4.00	1.50	2.00	2.50	3.00	3.50	4.00	2.00	2.50	3.00	3.50	4.00	2.00	2.50	3.00	3.50	4.00	
H	0.18	0.23	0.28	0.33	0.38	0.43	0.19	0.24	0.29	0.34	0.39	0.44	0.19	0.24	0.29	0.34	0.39	0.44	0.25	0.30	0.35	0.40	0.45	0.25	0.30	0.35	0.40	0.45	
b ₁	0.45	0.57	0.70	0.82	0.95	1.07	0.46	0.59	0.71	0.84	0.96	1.09	0.48	0.60	0.73	0.85	0.98	1.10	0.42	0.75	0.87	1.00	1.13	0.63	0.75	0.88	1.00	1.13	
b ₂	1.13	1.30	1.48	1.65	1.83	2.00	1.15	1.33	1.50	1.68	1.85	2.03	1.17	1.34	1.52	1.69	1.87	2.04	1.37	1.55	1.72	1.90	2.08	1.38	1.56	1.75	1.90	2.08	
B ₁	1.93	2.10	2.28	2.45	2.63	2.80	1.95	2.13	2.30	2.48	2.65	2.83	1.97	2.14	2.32	2.49	2.67	2.84	2.17	2.35	2.52	2.70	2.88	2.18	2.36	2.53	2.70	2.88	
B ₂																													

NOTES:-

1. ABUTMENT AND WING WALL SECTIONS ARE APPLICABLE FOR A MINIMUM BEARING CAPACITY OF THE SOIL OF 16 ST/M². FOR SOILS HAVING LOWER BEARING CAPACITY THE SECTIONS SHOULD BE INCREASED SUITABLY.
2. ABUTMENT AND WING WALL SECTIONS FOR INTERMEDIATE HEIGHTS TO BE ADOPTED SUITABLY.
3. THE VARIOUS DIMENSIONS TO BE SUITABLY ADJUSTED TO SUIT THE SIZE OF BRICKS WHERE NECESSARY.
4. THE SECTIONS ARE APPLICABLE FOR CULVERTS DESIGNED FOR IRC CLASS 70R OR 2 LANES OF CLASS A LOADING, WHICHEVER IS SEVERER, WITHOUT PROVISION OF APPROACH SLABS.
5. THE SECTIONS SHALL BE IN CEMENT CONCRETE 1:3:6, BRICK MASONRY IN CEMENT MORTAR 1:3 OR COURSED TUBBLE MASONRY (IF NO SORT) IN CEMENT MORTAR 1:3. THE FOUNDATION CONCRETE SHALL BE IN CEMENT CONCRETE 1:3:6.

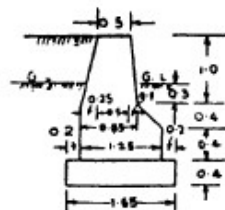

WING WALL SECTION AT LOW END (FOR ALL SPANS)

ABUTMENT AND WING WALL SECTIONS FOR CULVERTS



BLANK

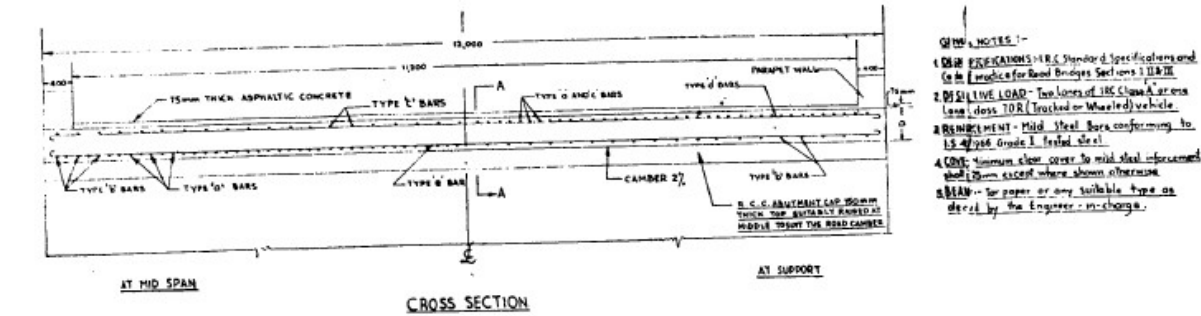

- GENERAL NOTES:-
1. REFER SPECIFICATIONS I.R.C. Standard Specifications and Code for Reinforcement for Road Bridges Section 3.1.1.1.1.1.1.
 2. DESIGN LIVE LOAD - Two lanes of IRC Class A (or less) Lane class TOR (Tracked or Wheeled) vehicle.
 3. REINFORCEMENT - Mild Steel Bars conforming to IS 4766 Grade I, tested steel.
 4. COVER - Minimum clear cover to mild steel reinforcement shall be 25mm except where shown otherwise.
 5. BEAR - For paper or any suitable type as decided by the Engineer-in-charge.

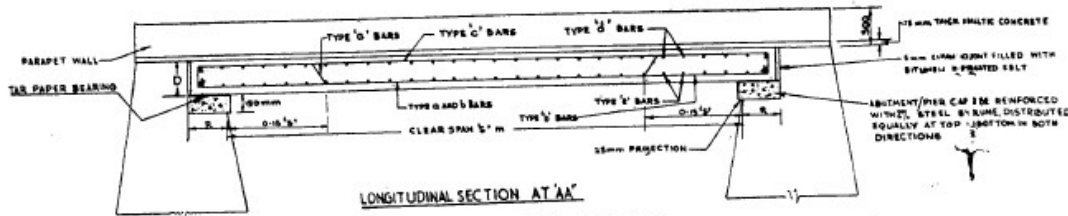

CEMENT CONCRETE ORDINARY MIX 1:2:4

CLEAR SPAN OF SLAB 'S' (m)	MEASURING LENGTH OF LANE FOOTING	OVERALL LENGTH OF SLAB 'L' (m)	OVERALL THICKNESS OF SLAB 'D' (mm)	STEEL IN LONGITUDINAL DIRECTION				STEEL IN TRANSVERSE DIRECTION				TOTAL QUANTITY OF M.S. REINFORCEMENT PER SPAN IN TONNES (INCLUDING OF 5% FOR LAPS AND WASTAGES)	TOTAL QUANTITY OF CONCRETE PER SPAN IN CUBIC METRES																									
				TYPE 'G' BARS		TYPE 'B' BARS		TYPE 'C' BARS		TYPE 'B' BARS				TYPE 'D' BARS																								
				DIA (mm)	SPACING (mm)	NO. OF BARS	X (m)	Y (m)	Z (m)	DIA (mm)	SPACING (mm)			NO. OF BARS	J (m)	K (m)	L (m)	M (m)																				
1-0	300	1.6	190	16	300	40	0-153	0-75	0-7	1-32	17-40	16	300	40	1-54	0-83	1-32	10	300	40	1-55	0-16	1-97	79.48	16	150	11	11-85	12-235	11-54	10	300	6	11-89	12-127	1-19	0-582	3-65
1-5	300	2-1	220	16	180	30	0-202	0-20	0-5	1-44	19-86	15	150	80	1-77	2-12	1-78	10	300	40	2-05	0-13	2-57	101.88	16	150	14	11-85	12-235	11-54	10	300	7	11-89	12-127	1-19	0-648	5-55
1-0	300	2-4	240	16	150	30	0-151	0-140	1-40	2-78	23-4	15	150	80	2-47	2-12	2-04	10	300	40	2-55	0-15	3-07	123.48	16	125	11	11-85	12-235	11-54	10	300	9	11-89	12-127	1-19	1-117	7-48
1-0	300	3-4	303	16	150	80	0-450	0-31	1-10	3-87	29-48	15	150	80	3-45	4-83	3-04	10	300	40	3-55	0-05	4-21	168.68	16	125	2-9	11-85	12-235	11-54	10	300	12	11-89	12-127	1-19	1-841	13-20
4-0	300	4-4	310	16	150	80	0-410	0-47	2-8	5-17	40-92	15	150	80	4-45	4-83	3-04	10	300	40	4-59	0-28	5-27	213.88	16	125	3-7	11-85	12-235	11-54	10	300	15	11-89	12-127	1-19	2-506	20-41
5-0	400	5-8	420	20	150	80	0-675	0-47	3-5	6-74	51-52	15	150	80	5-65	6-03	4-24	10	300	40	5-76	0-33	6-47	265.88	16	125	4-7	11-85	12-235	11-54	10	300	19	11-89	12-127	1-19	3-402	29-26
6-0	400	6-8	476	20	150	80	0-81	0-52	4-2	14-88	65-94	20	150	80	6-43	7-10	5-29	10	300	40	6-75	0-30	7-37	310.28	16	125	5-5	11-85	12-235	11-54	10	300	23	11-89	12-127	1-19	4-513	38-80

CONTROLLED CONCRETE M 200

CLEAR SPAN OF SLAB 'S' (m)	MEASURING LENGTH OF LANE FOOTING	OVERALL LENGTH OF SLAB 'L' (m)	OVERALL THICKNESS OF SLAB 'D' (mm)	STEEL IN LONGITUDINAL DIRECTION				STEEL IN TRANSVERSE DIRECTION				TOTAL QUANTITY OF M.S. REINFORCEMENT PER SPAN IN TONNES (INCLUDING OF 5% FOR LAPS AND WASTAGES)	TOTAL QUANTITY OF CONCRETE PER SPAN IN CUBIC METRES																									
				TYPE 'G' BARS		TYPE 'B' BARS		TYPE 'C' BARS		TYPE 'B' BARS				TYPE 'D' BARS																								
				DIA (mm)	SPACING (mm)	NO. OF BARS	X (m)	Y (m)	Z (m)	DIA (mm)	SPACING (mm)			NO. OF BARS	J (m)	K (m)	L (m)	M (m)																				
1-0	300	1.6	150	16	180	66	0-259	0-11	0-7	1-36	17-5	12	180	66	1-75	1-11	1-02	10	300	33	1-55	0-04	1-90	62.93	16	125	12	11-85	12-235	11-54	10	300	5	11-89	12-127	1-19	0-662	2-88
1-5	300	2-1	180	16	180	66	0-344	0-14	0-5	2-42	18-18	16	180	66	1-95	1-33	1-19	10	300	23	2-95	0-09	2-44	81.41	16	100	21	11-85	12-235	11-54	10	300	7	11-89	12-127	1-19	1-054	4-54
2-0	300	2-6	215	12	150	80	0-344	0-24	1-4	3-84	23-94	16	150	80	2-45	2-83	2-04	10	300	40	2-55	0-02	3-07	121.48	16	100	2-6	11-85	12-235	11-54	10	300	9	11-89	12-127	1-19	1-248	6-71
3-0	300	3-6	275	16	150	80	0-440	0-24	2-1	5-00	37-14	16	150	80	3-46	3-81	3-04	10	300	40	3-59	0-05	4-17	166.28	16	150	2-4	11-85	12-235	11-54	10	300	12	11-89	12-127	1-19	2-088	11-88
4-0	300	4-6	345	16	150	80	0-540	0-24	2-8	7-04	49-22	16	150	80	4-45	4-84	3-04	10	300	40	4-58	0-29	5-27	211.88	16	150	3-0	11-85	12-235	11-54	10	300	15	11-89	12-127	1-19	2-556	19-05
5-0	400	5-8	395	20	150	80	0-74	0-44	3-9	9-04	69-22	20	150	80	6-43	7-10	5-29	10	300	40	6-75	0-05	6-57	243.88	16	150	3-9	11-85	12-235	11-54	10	300	19	11-89	12-127	1-19	3-703	27-50
6-0	400	6-8	443	16	150	80	0-840	0-31	4-2	17-35	80-0	25	150	80	6-43	7-10	5-29	10	300	40	6-75	0-35	7-37	307.88	16	150	4-4	11-85	12-235	11-54	10	300	23	11-89	12-127	1-19	4-581	36-30

REINFORCEMENT DETAILS OF R_c SLAB FOR CULVERTS

BLANK



GOVERNMENT OF ARUNACHAL PRADESH
PUBLIC WORKS DEPARTMENT
EASTERN ZONE (PWD)

VOLUME-II
(FORM OF BID & BILL OF QUANTITY)

BID NO. TDW/NIT-15/SPA/2022-23/03

“Construction of C.C. Road in Tezu Township”.

Certified that this NIT contains 18 pages including cover pages in Volume-II.

A handwritten signature in blue ink, consisting of a stylized 'E' followed by a horizontal line.

Executive Engineer
Tezu Division, PWD
Tezu

Sd/-

Superintending Engineer
Tezu Circle, PWD, Tezu
Tezu

Sd/-
CHIEF ENGINEER,
EASTERN ZONE, PWD,
NAMSAI, AP

BLANK

SECTION – 6
FORM OF BID

BLANK

LETTER HEAD OF BIDDER

FORM OF BID

Description of the Works:-

“Construction of C.C. Road in Tezu Township”

Bid No. TDW/NIT-15/SPA/2022-23/03

To,

The Executive Engineer,
Tezu Division,PWD, AP,
Tezu.

1. We offer to execute the work described above, remedy, and defects therein in conformity with the conditions of Contract, Specifications, drawings, Bill of Quantities and Addenda for the sum(s) of **Rs.-----Rupees -----**
----- only.
2. We undertake, if our bid is accepted, to commence the work as soon as is reasonably possible after the receipt of the Engineer’s notice to commence, and to complete the whole of the works comprised in the contract within the time stated in the document.
3. We agree to abide by this Bid for the period of 120 days from the last date fixed for receiving the same, and it shall remain binding upon us and may be accepted at any time before the expiration of that period.
4. Unless and until a formal Agreement is prepared and executed the Bid, together with your written acceptance thereof, shall constitute a binding contract between us:-
5. We understand that you are not bound to accept the lowest or any tender you may receive.

Dated this _____ day of _____ 2022.

Signature _____ in the capacity of -----duly
authorized to sign bids for and on behalf of M/s. _____

(In block capital or typed)

Address:-

Witness

Address

Occupation

SECTION – 7
BILL OF QUANTITIES

BLANK